













COLIBRI

Ö | Š | Ā | Á | S | Ó | Ú | Ą | ç | à | é | Ò | | à | á | ä | å | ã | ê | ç | Ë | | ä

Accessorio  
OPTIONAL

							
Watt 600	h. max. 150 mm. Gastronorm 2/1 - 1/1 - 2/3 - 1/2 - 1/3	°C +4/+10		230V/1/50Hz		R 404a	Kg. 95

Colibri

Accessorio  
OPTIONAL

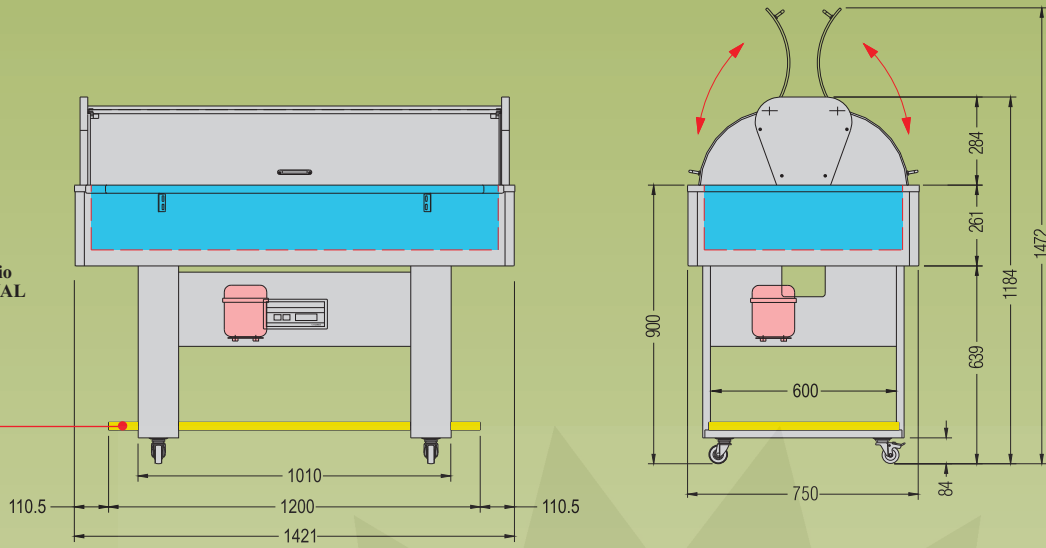

Apertura **MANUALE** delle cupole • **MANUAL** opening of the domes • Ouverture **MANUEL** des coupoles • **MANUELLES** öffnung der Kuppeln • Apertura **MANUAL** de las cúpulas

\* **Vassoio unico per piatti pronti e pasticceria (fornito a richiesta)** • For ready-to-serve dishes or pastry (supplied on request) • Plateau pour plats cuisines ou pâtisserie (fourni sur demande)  
Ein Einziges Tablett für Patisserie oder Fertige Speisen (Lieferbar auf Anfrage) • Bandeja para platos listos o para pastelerías para llevar (bajo demanda)

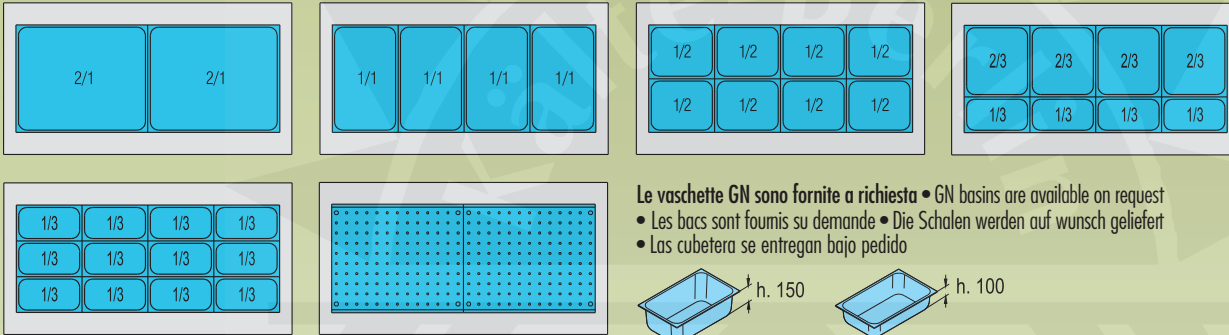

Le vasette GN sono fornite a richiesta • GN basins are available on request  
• Les bacs sont fournis su demande • Die Schalen werden auf Wunsch geliefert  
• Las cubetera se entregan bajo pedido

\* LxPxH: 1270x505x90 mm

Pegaso

Accessorio  
OPTIONAL

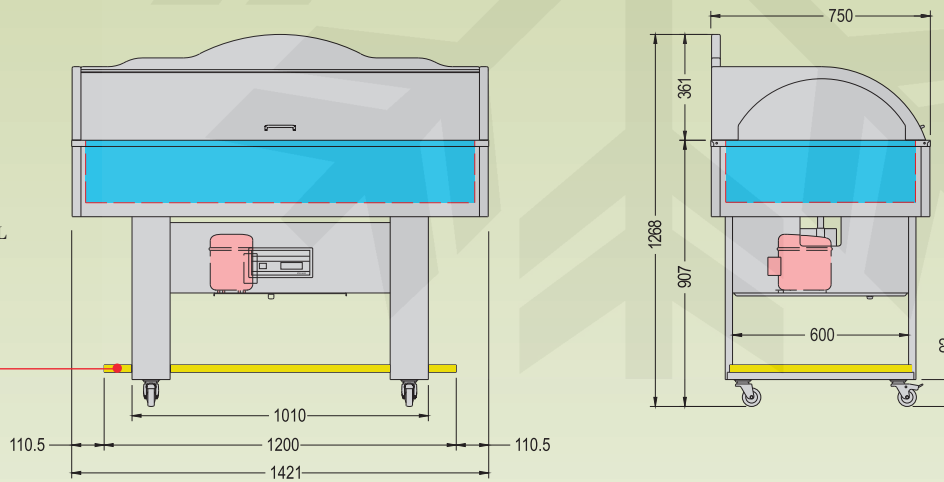

\* **Vassoio unico per piatti pronti e pasticceria (fornito a richiesta)** • For ready-to-serve dishes or pastry (supplied on request) • Plateau pour plats cuisines ou pâtisserie (fourni sur demande)  
Ein Einziges Tablett für Patisserie oder Fertige Speisen (Lieferbar auf Anfrage) • Bandeja para platos listos o para pastelerías para llevar (bajo demanda)

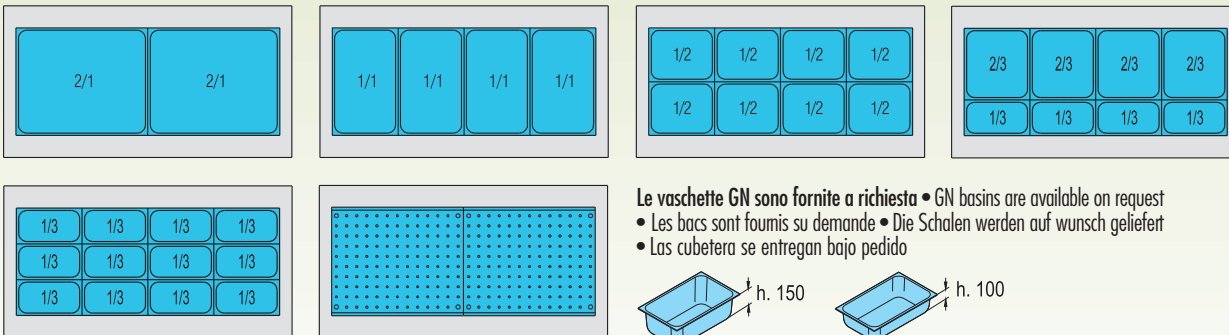

Le vasette GN sono fornite a richiesta • GN basins are available on request  
• Les bacs sont fournis su demande • Die Schalen werden auf Wunsch geliefert  
• Las cubetera se entregan bajo pedido

\* LxPxH: 1270x505x90 mm



# COLIBRI

INSTALLAZIONE E USO  
INSTALLATION AND USE  
ZUSAMMENBAU  
UND BETRIEB  
INSTALACIÓN Y USO  
INSTALLATION ET  
MODE D'EMPLOI  
INSTALLATIE EN GEBRUIK  
INSTALAÇÃO E USO  
INSTALLATION OCH BRUK  
INSTALLATIONS OG  
BETJENINGS  
ASENNUS JA KÄYTTÖ  
INSTALLATIE EN GEBRUIK  
ΤΟΠΟΘΕΤΗΣΗ ΚΑΙ ΧΡΗΣΗ  
INSTALACE A POUŽITÍ  
UZSTĀDĪŠANA UN  
EKSPLOATĀCIJA  
INSTALACIJA IN UPORABA  
PAIGALDAMINE JA  
KASUTAMINE  
BEÉPÍTÉS ÉS HASZNÁLAT  
INŠTALÁCIA A POUŽITIE  
INSTALACJA I  
UŻYTKOWANIE  
ISTALLAZJONI U UŻU  
INSTALIAVIMAS IR  
NAUDOJIMAS



MANUTENZIONE  
MAINTENANCE  
INSTANDHALTUNG  
MANTENIMIENTO  
ENTRETIEN  
ONDERHOUD  
MANUTENÇÃO  
UNDERHÅLL  
VEDLIGEHOLDEL-  
SEANVISNING  
HUOLTO-OHJEET  
ONDERHOUD  
ΣΥΝΤΗΡΗΣΗ  
ÚDRŽBA  
APKOPE  
VZDRŽEVANJE  
HOOLDUS  
KARBANTARTÁS  
ÚDRŽBA  
KONSERWACJA  
MANUTENZJONI  
TECHNINIS APTARNAVIMAS

Italiano	I
English	UK
Deutsch	D
Español	E
Français	F
Nederlands	NL
Português	P
Svenska	S
Dansk	DK
Suomi	FIN
Vlaams	B
Ellinika	GR
Čeština	CZ
Esti keel	EE
Latviešu valoda	LV
Lietuvių kalba	LT
Magyar	H
Malti	M
Polski	PL
Slovenčina	SK
Slovenščina	SLO



- I
- UK
- D
- E
- F
- NL
- P
- S
- DK
- FIN
- B
- GR
- CZ
- EE
- LV
- LT
- H
- M
- PL
- SK
- SLO

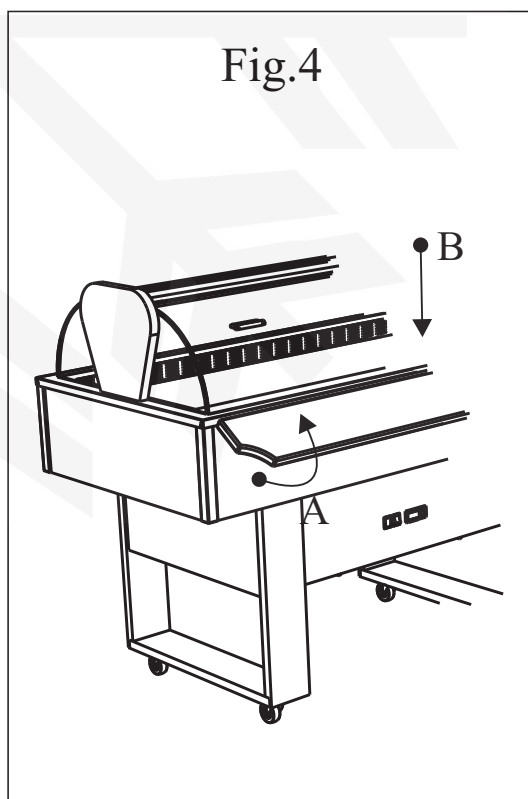
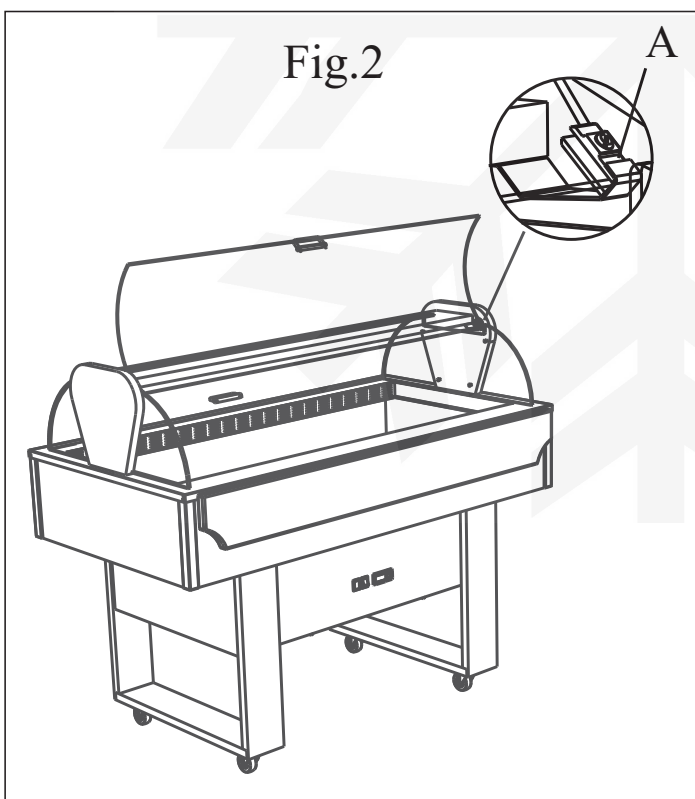
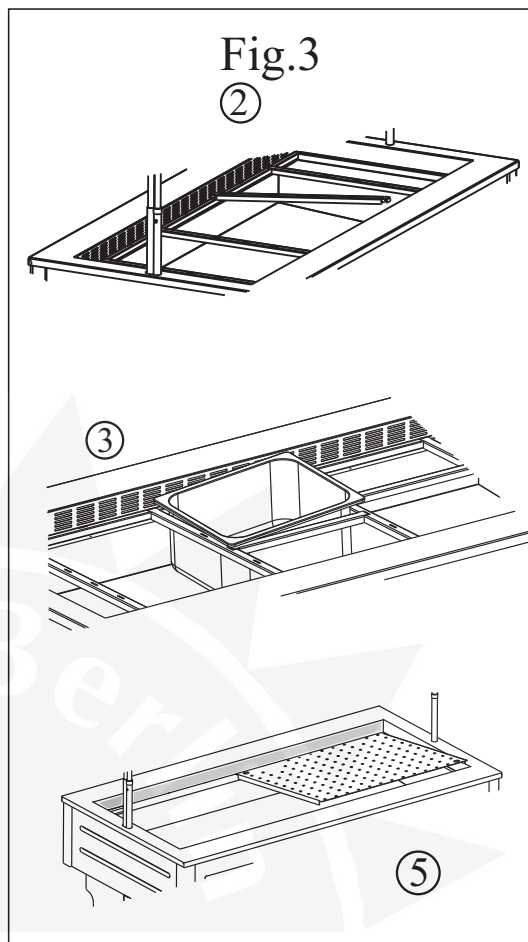
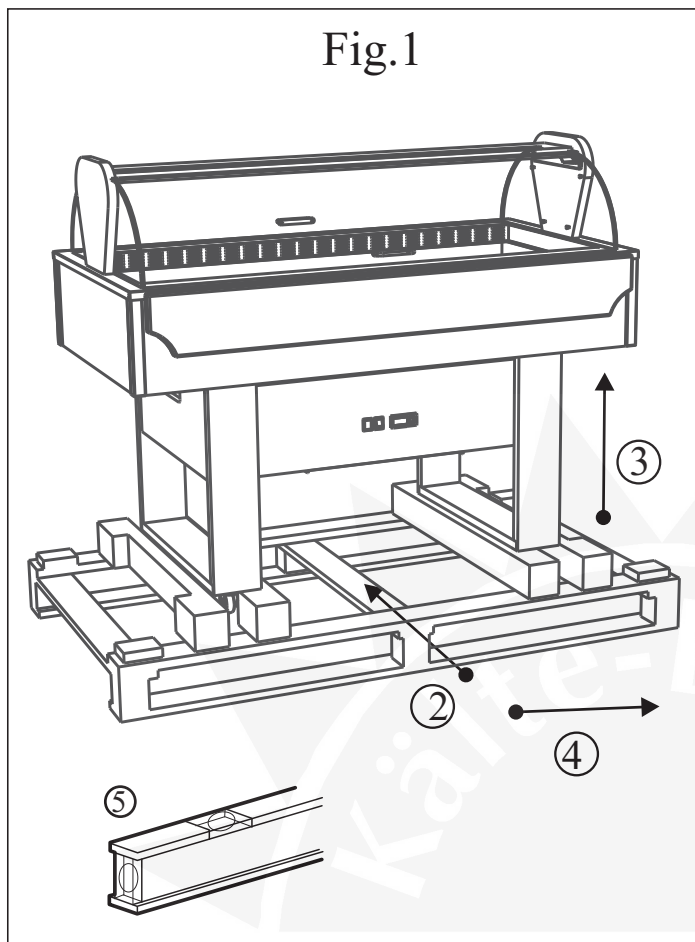

Fig.5

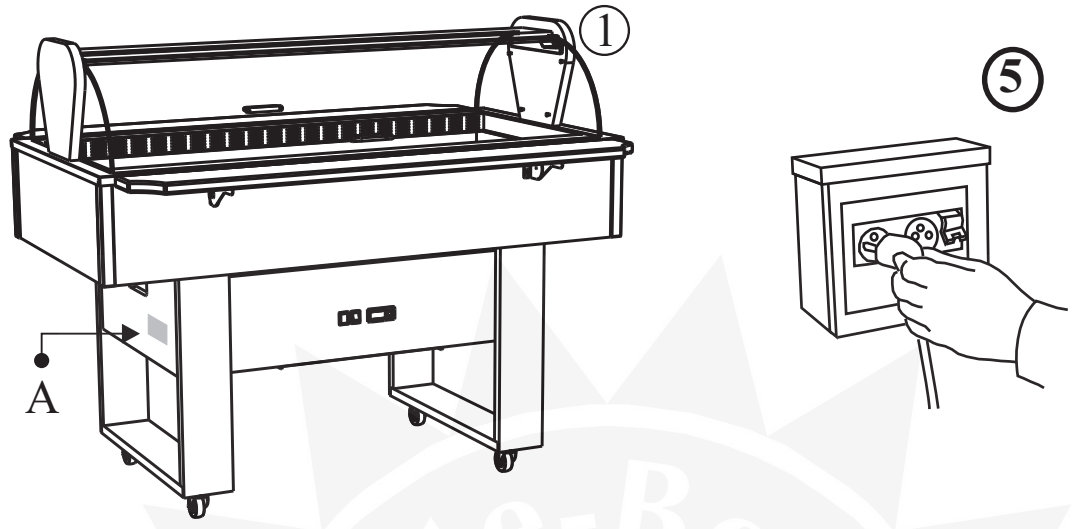
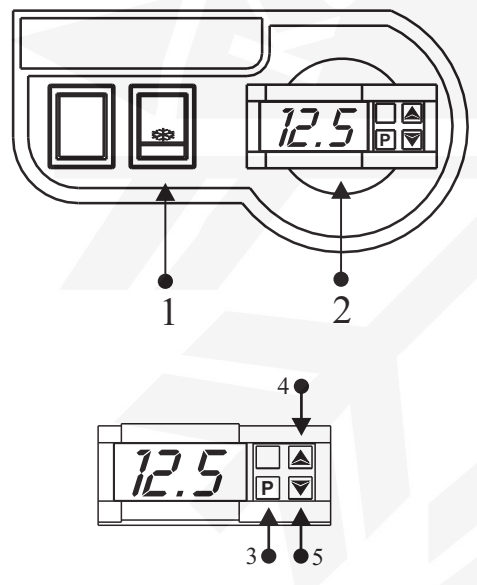
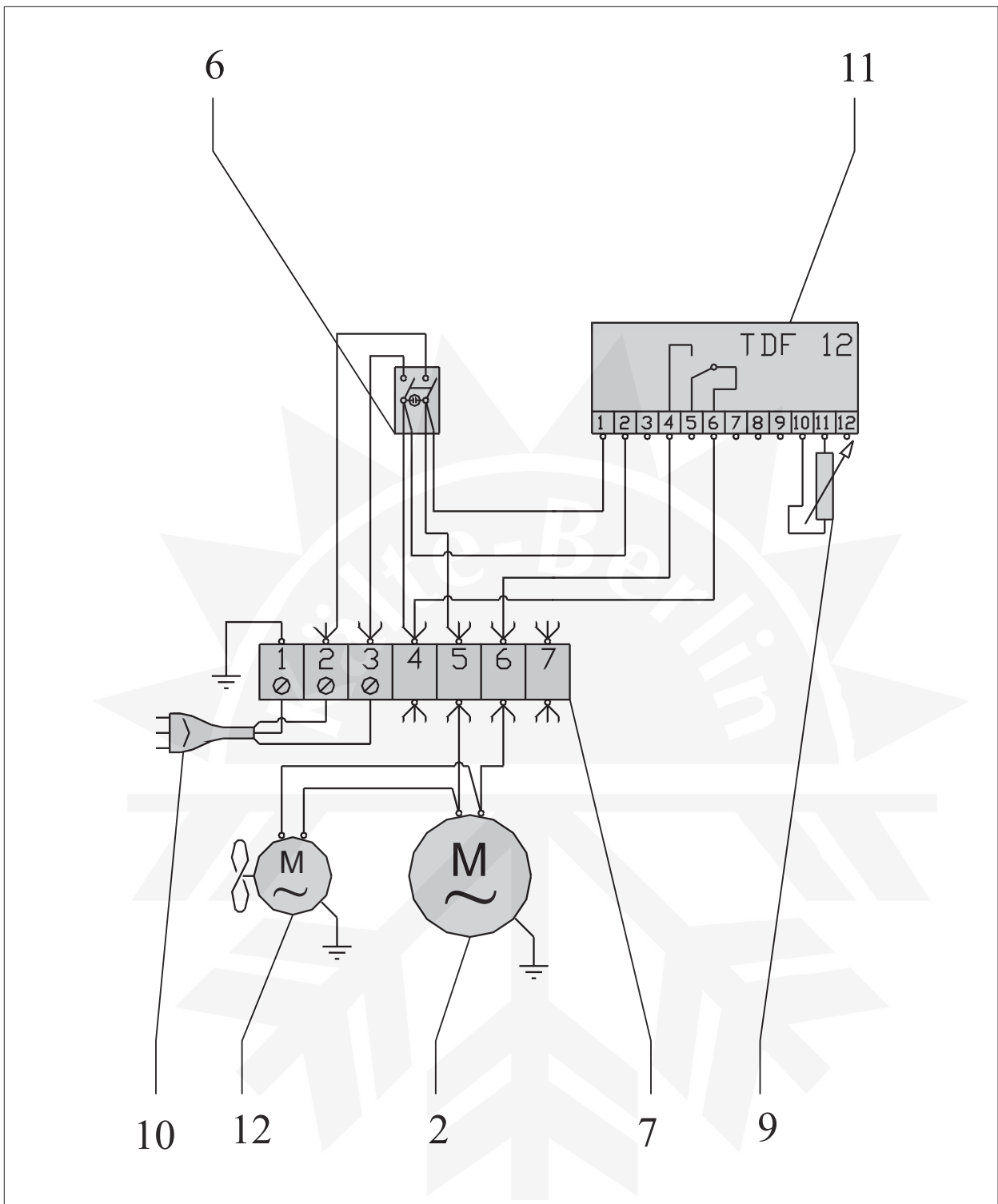

Fig.6



- I
- UK
- D
- E
- F
- NL
- P
- S
- DK
- FIN
- B
- GR
- CZ
- EE
- LV
- LT
- H
- M
- PL
- SK
- SLO





- I
- UK
- D
- E
- F
- NL
- P
- S
- DK
- FIN
- B
- GR
- CZ
- EE
- LV
- LT
- H
- M
- PL
- SK
- SLO



- I
- UK
- D
- E
- F
- NL
- P
- S
- DK
- FIN
- B
- GR
- CZ
- EE
- LV
- LT
- H
- M
- PL
- SK
- SLO

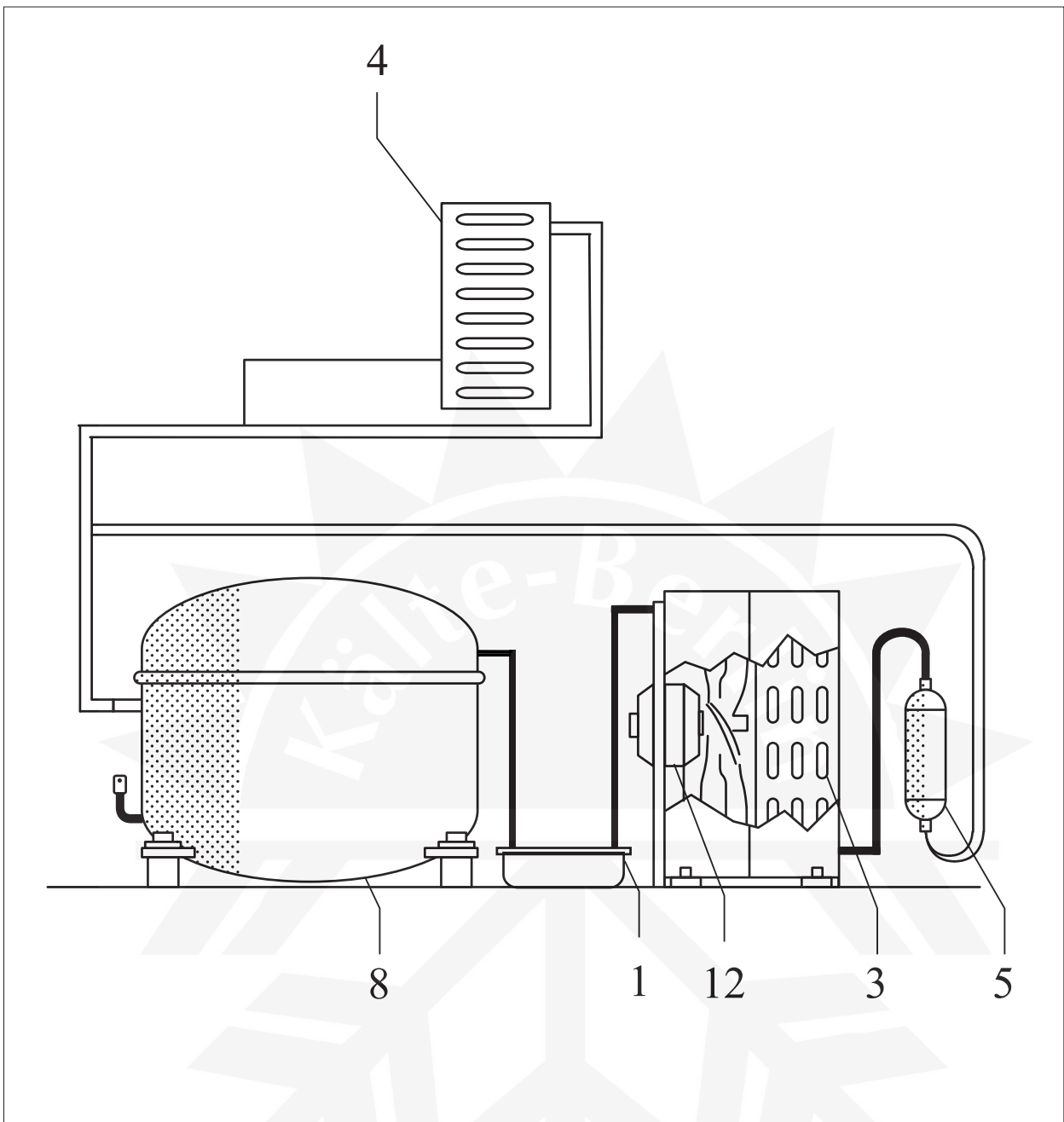

I

UK

D

E

F

NL

P

I

1)Bacinella 2)Compressore 3)Condensatore 4)Evaporatore 5)Filtro 6)Interruttore 7)Morsettiera  
8)Motocompressore 9)Sonda 10)Spina 11)Termostato 12)Ventola condensatore

UK

1)Tray 2)Compressor 3)Condenser 4)Evaporator 5)Filter 6)Switch 7)Terminal board 8)Motor compressor  
9)Probe 10)Plug 11)Thermostat 12)Condenser fan

D

1)Wanne 2)Kompressor 3)Verflüssiger 4)Verdampfer 5)Filter 6)Schalter 7)Klemmleiste  
8)Motorkompressor 9)Sensor 10)Netzsteckdose 11)Thermostat 12)Gebläse Verflüssiger

E

1)Bandeja 2)Compresor 3)Condensador 4)Evaporador 5)Filtro 6)Interruptor 7)Caja de bornes  
8)Motocompresor 9)Sonda 10)Enchufe 11)Termostato 12)Ventilador condensador

F

1)Bassine 2)Compresseur 3)Condenseur 4)Évaporateur 5)Filtre 6)Interrupteur 7)Bornier  
8)Motocompresseur 9)Sonde 10)Prise de courant 11)Thermostat 12)Ventilateur condenseur

NL

1)Teiltje 2)Compressor 3)Koelinstallatie 4)Verdamper 5)Filter 6)Schakelaar 7)Klemmenbord  
8)Motorcompressor 9)Sonde 10)Stekker 11)Thermostaat 12)Ventilator koelinstallatie

P

1)Cuba 2)Compressor 3)Condensador 4)Evaporador 5)Filtro 6)Interruptor 7)Terminal de bornes  
8)Compressor motorizado 9)Sonda 10)Placa de união 11)Termostato 12)Ventilador condensador





- I
- UK
- D
- E
- F
- NL
- P
- S
- DK
- FIN
- B
- GR
- CZ
- EE
- LV
- LT
- H
- M
- PL
- SK
- SLO

- I** Manuale del manutentore
- UK** Maintenance manual
- D** Wartungshandbuch
- E** Manual de mantenimiento
- F** Manuel du préposé à l'entretien
- NL** Onderhoudshandleiding
- P** Manual do técnico de manutenção
- S** Manual för underhållspersonalen
- DK** Vejledning til vedligeholdelsespersonale
- FIN** Huolto-opas
- B** Handleiding van de persoon belast met het onderhoud
- GR** Εγχειρίδιο συντηρητή
- CZ** Pokyny pro údržbu
- EE** Hooldusjuhend
- LV** Instrukcija tehniskās apkopes darbiniekam
- LT** Techninio aptarnavimo darbuotojo vadovas
- H** Karbantartási kézikönyv
- M** Manwal għall-manutenzjoni
- PL** Podrecznik obsługi konserwacyjnej
- SK** Príručka pre údržbára
- SLO** Priročnik za vzdrževalno osebje



Fig.1

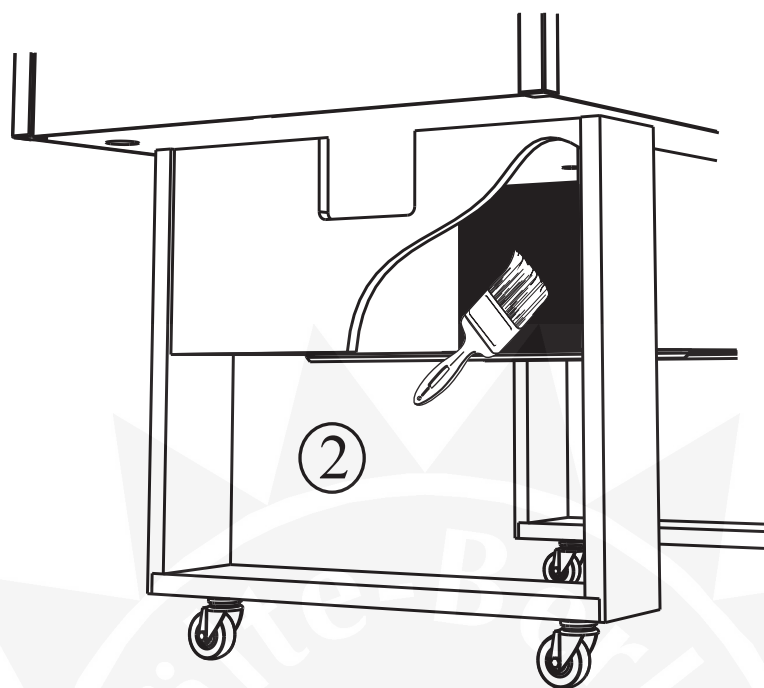

- I
- UK
- D
- E
- F
- NL
- P
- S
- DK
- FIN
- B
- GR
- CZ
- EE
- LV
- LT
- H
- M
- PL
- SK
- SLO



**1. PULIZIA DEL CONDENSATORE**

1. Togliere l'alimentazione elettrica, agendo sull'interruttore a protezione della presa e sfilando poi la spina dalla presa stessa. 2. Abbassatevi e nella parte sottostante la vasca vedrete il condensatore. 3. Con un pennello eliminare lo strato di pulviscolo dalle alette del condensatore. 4. Con l'aspirapolvere togliere la polvere residua. 5. Ripristinare l'alimentazione elettrica (Vedi Fig 1)

**2. PULIZIA INTERNA e DEGLI EVAPORATORI**

1. Togliere l'alimentazione. 2. Operare uno sbrinamento totale. Rimuovere la merce ponendola in altro luogo adeguatamente refrigerato alla stessa temperatura. 3. Togliere il tappo dal centro del fondo vasca (come illustrato in Capitolo 4). 4. Lasciare sbrinare gli evaporatori, evitando l'uso di corpi metallici taglienti o appuntiti nel tentativo di rimuovere il ghiaccio. 5. Pulire le pareti e gli accessori, facendo attenzione alle alette dell'evaporatore in quanto taglienti, con una spugna umida d'acqua e di un po' di bicarbonato di sodio ed asciugare accuratamente.

**1. CLEANING THE CONDENSER**

1. Use the power socket protection switch to switch off the power supply and then remove the plug from the socket. 2. On the bottom, under the tank you will see the condenser. 3. Use a paintbrush to remove the dust from the condenser's fins. 4. Use a vacuum cleaner to remove any remaining dust. 5. Switch the power back on (see figure 1).

**2. INTERNAL CLEANING AND EVAPORATOR CLEANING**

1. Switch off the appliance. 2. Defrost the appliance. Remove goods and store them in another suitable appliance running at the same temperature. 3. Remove the plug from the centre of the tank (as shown in Chapter 4). 4. Allow the evaporators to defrost. Do not use sharp or pointed metal tools to remove the ice. 5. Clean sides and accessories with a sponge dipped in water and a little sodium bicarbonate and dry with care.

**1. KONDENSATORREINIGUNG**

1. Schalten Sie den Strom ab, indem Sie den Schutzschalter der Steckdose betätigen und dann den Stecker aus eben der Steckdose ziehen. 2. Wenn Sie sich bücken, können Sie im Bereich unter der Wanne den Kondensator sehen. 3. Mit einem Pinsel den Staub von den Lamellen des Kondensators entfernen. 4. Mit einem Staubsauger den restlichen Staub beseitigen. 5. Stromversorgung wieder herstellen (siehe Abb. 1)

**2. REINIGUNG DES INNENBEREICHS und DER VERDAMPFER**

1. Strom wie abschalten. 2. Vollkommen abtauen lassen. Die Ware entfernen und an einem anderen, ausreichend gekühlten Ort mit gleicher Temperatur unterbringen. 3. Verschluss im Zentrum des Wannenbodens entfernen (wie im Kapitel 4 gezeigt). 4. Verdampfer abtauen lassen, wobei die Verwendung von scharfen oder spitzen Metallgegenständen zum Entfernen des Eises vermieden werden sollte. 5. Reinigen Sie die Wände und die Zubehörteile mit einem mit Wasser befeuchteten Schwamm und etwas Natron und achten Sie darauf, sich nicht an den scharfen Lamellen des Verdampfers zu schneiden. Sorgfältig abtrocknen.



## Bedienungshandbuch:

- 1)Verpackungsöffnung.
- 2)Haubenöffnung
- 3)Reinigung der innenwanne
- 4)Aussenreinigung
- 5)Stützende abstandshalter der schalen und gebäckablagen
- 6)Ablageflächen
- 7)Verbindung mit dem stromnetz
- 8)Einstellung
- 9)Betriebskontrolle

## Wartungshandbuch (S. 48):

- 1)Kondensatorreinigung
- 2)Reinigung des innenbereichs und der verdampfer
- 3)Elektroschema, kühlanlageschema

D

## ! SICHERHEITSHINWEISE

**Wichtig! Aus Sicherheitsgründen muß man die Betriebsanleitung ständig am Einsatzort der Vitrine griffbereit aufbewahren.** 1. Arbeiten mit der Maschine dürfen nur von zuverlässigen Erwachsenen durchgeführt werden. Kinder dürfen keinesfalls die Vitrine berühren, in der Nähe der Vitrine spielen oder an den Regelschaltern spielen. 2. Es dürfen aus Sicherheitsgründen keine Modifikationen an der Vitrine vorgenommen werden. 3. Arbeiten an elektrischen Teilen für die Montage der Vitrine dürfen nur von einer Elektrofachkraft oder unter Aufsicht von Fachleuten durchgeführt werden. 4. Die Vitrine niemals selbstständig reparieren. Die durch unqualifiziertes Personal durchgeführten Reparaturen können Schäden und Funktionsstörungen verursachen. 5. Der technische Kundendienst dieser Vitrine darf nur von einem Vertragshändler - Kundendienstservicestelle durchgeführt werden. Nur Originalersatzteile verwenden! 6. Das Gerät ist nur für Lebensmittel geeignet! 7. Eine Haftung und Gewährleistung ist bei Nichtbeachtung dieser Unfallverhütungshinweise ausgeschlossen. Änderungen und Verbesserungen ohne vorherige Benachrichtigung vorbehalten. 8. Aufstellung der vitrine bei direkter sonneneinstrahlung vermeiden. 9. Gerät nicht in der Nähe von Wärmequellen wie Öfen, Heizkörper usw. nicht aufstellen. 10. Sicherstellen, daß der abstand der Lüftungsgitter am Aggregat von der Wand mindestens 30cm beträgt. 11. Denken Sie daran, dass die ausgestellten Produkte nicht über die Ablagen oder Gitter hinausstrecken dürfen. 12. Sollte es durch die Luftfeuchtigkeit oder die zu kühlenden Produkte zu außergewöhnlicher Bildung von Eis auf dem Verdampfer kommen, empfehlen wir, den Kompressor auszuschalten und die Ware während des Abtauens bei gleicher Temperatur in dem vorgesehenen Behälter aufzubewahren; andernfalls arbeitet der Kompressor ununterbrochen und verursacht einen unnötigen Energieverbrauch sowie niedrige Leistung. 13. Die Tür für mindestens 10 cm. unbedingt offen lassen, falls die Vitrine stillstehend und unbenutzt bleiben sollte.

### 1. VERPACKUNGSÖFFNUNG

**KARTONVERPACKUNG 1a.** Das Band durchschneiden und den Karton nach oben herausziehen.

**HOLZKISTENVERPACKUNG 1b.** Vorsichtig die Nägel aus den Holzbrettern ziehen. 2. Die Gabeln des Gabelstaplers zwischen Gerät und Palette oder Kiste schieben. 3. Gerät anheben. 4. Palette oder Kiste entfernen. 5. Gerät auf eine ebene Abstellfläche setzen. 6. Es ist möglich, die Räder des Geräts mit der Bremse zu blockieren. 7. Achten Sie darauf, dass sich nichts mehr in der Verpackung befindet, bevor Sie sie fortwerfen. 8. Trennen Sie die Verpackung nach Materialien, um die Entsorgung zu erleichtern (siehe Abbildung 1).

### 2. HAUBENÖFFNUNG

Fassen Sie den Handgriff und heben Sie die Haube an, bis sie blockiert (A) (siehe Abb. 2)

### 3. REINIGUNG DER INNENWANNE

1. Entfernen Sie die Schutzfolie vom Boden und von den Rändern. 2. Säubern Sie den Innenbereich und die Scheiben mit einem weichen Schwamm und neutralen Reinigungsmitteln.

### 4. AUSSENREINIGUNG

1. Vermeiden Sie es unbedingt, abrasive Produkte oder Schleifschwämme zu verwenden. 2. Benutzen Sie nur einen weichen, befeuchteten Schwamm. 3. Holzflächen mit im Handel erhältlichem Spezialreiniger reinigen. Es handelt sich um lösungsmittelfreie Wasseremulsionen. 4. Mit einem sauberen Tuch abtrocknen.

### 5. STÜTZENDE ABSTANDSHALTER DER SCHALEN UND GEBÄCKABLAGEN

1. Entfernen Sie die Schutzfolie von den Abstandshaltern. 2. Die längeren Abstandhalter an den Rändern der Wanne anbringen. 3. Befestigen Sie die Schalen nach Belieben auf den dafür vorgesehenen Abstandshaltern. 4. Für die Konditoreimodelle nur die Montage der Gebäckablage aus rostfreiem Stahl ausführen, indem Sie sie auf den Rändern auflegen (die Schalen und die Gebäckablagen aus rostfreiem Stahl werden auf Anfrage geliefert) (siehe Abb. 3).



## 6. ABLAGEFLÄCHEN

1. Fassen Sie den unteren Rand der Ablagen mit den Händen und drehen Sie sie nach oben (A), bis sie sich in horizontaler Stellung befinden. 2. Drücken Sie den Rand nahe der Wanne (B) nach unten, bis sich jede einzelne Fläche blockiert. (Siehe Abb. 4)

## 7. VERBINDUNG MIT DEM STROMNETZ

1. Netzspannung und -frequenz müssen mit den auf dem am Gerät angebrachten Typenschild (A) angegebenen Werten übereinstimmen. 2. Überprüfen Sie, dass die Steckdose: **a)** Mit einer Erdleitung ausgestattet ist. **b)** Zu dem auf dem Schild angegebenen Nennstrom passt. **c)** Gemäß den IEC-Normen mit einer Schutzvorrichtungen ausgerüstet ist: - Thermomagnetschalter mit  $I_n$  = auf dem Schild angegebenem Nennwert. - Differenzial mit einer Ansprechempfindlichkeit von  $I_d = 30 \text{ mA}$ . 3. Versichern Sie sich, dass am Aufstellungsort keine Explosionsgefahr besteht (AD). 4. Versichern Sie sich, dass der Aufstellungsort für den Gebrauch des am Gerät angebrachten Speisekabels geeignet ist: Das angebrachte Kabel: "H05 VVF" ist für Innenräume vorgesehen. Für andere Aufstellungsorte muss das Kabel durch ein geeignetes ersetzt werden (z.B. mit dem Kabel HO 7 VV F für Außenbereiche).

**NB:** Wenn das Gerät während des Transports oder der Lagerung sich irrtümlicherweise in horizontaler oder umgedrehter Stellung befand, lassen sie es mindestens 3 Stunden lang in der richtigen Position ruhen, bevor sie es an das Stromnetz anschließen. 5. Stecker in die Steckdose stecken (keine Dreifachstecker oder Verminderer verwenden) (siehe Abbildung 5).

## 8. EINSTELLUNG

Das Gerät ist mit Einstellsteuerungen ausgestattet, die sich in auf der Vorderseite befinden.

1. **Kühlschalter:** Zum Einschalten der Kühlanlage. 2. **Thermometer:** Gibt die Temperatur im Inneren des Geräts an. **Thermostat:** Reguliert die Temperatur des Geräts. **a)** Das einmalige Drücken der Taste 3 **"SET oder P"** ermöglicht das Ablesen der voreingestellten Temperatur, die durch Drücken der Taste 4 **"UP"** oder 5 **"DOWN"** geändert werden kann. (siehe Abbildung 6).

## 9. BETRIEBSKONTROLLE

1. Der Stecker muss eingesteckt sein. 2. Der Schalter der Kühlanlage muss eingeschaltet sein und das grüne Licht muss leuchten. 3. Das Thermometer muss einen für die Waren geeigneten Temperaturwert anzeigen. 4. Das Gerät darf nicht der direkten Sonneneinstrahlung oder dem Licht von genau über dem Gerät angebrachten Hochleistungsstrahlern ausgesetzt sein. 5. Die Raumtemperatur darf nicht über  $+25^\circ\text{C}$  - RF 60% liegen, für die das Gerät zugelassen ist (Klimaklasse 3). 6. Im Inneren des Geräts dürfen keine direkten Luftströme bestehen, die von Türen, Fenstern, Ventilatoren oder Air-conditioning-Düsen herrühren.



# TDF 12

## MICROPROCESSOR-BASED DIGITAL ELECTRONIC FREEZER CONTROLLER



### OPERATING INSTRUCTIONS

Vr. 01 (I - GB) - cod.: ISTR 00251

**PREVIOUS STATEMENT:** In this manual are contained all the necessary information for a correct installation and the instructions for the use and the maintenance of the product; we recommend, therefore, to read carefully the following instructions. The maximum care has been used in the realisation of this document, anyway TECNOLOGIC S.p.A. does not assume any responsibility deriving from the use of itself. The same consideration has to be done for each person or Company involved in the creation of this manual. The herewith issue is an exclusive property of TECNOLOGIC S.p.A. which forbids any reproduction and divulgation, although partial, if not expressly authorised. TECNOLOGIC S.p.A. reserves the right to execute aesthetically and functional modifications, at any moment and without any notice.

#### INDEX

- 1 GENERAL DESCRIPTION
  - 1.1 FRONT PANEL
  - 1.2 INSTRUMENT CODE
- 2 TECHNICAL DATA
- 3 INSTALLATION
- 4 OPERATING MODE
  - 4.1 ON/OFF CONTROL
  - 4.2 COMPRESSOR PROTECTION FUNCTION
  - 4.3 DEFROST CONTROL
  - 4.4 MANUAL DEFROST
  - 4.5 ALARM FUNCTIONS
  - 4.6 DIGITAL INPUT
- 5 PROGRAMMING
  - 5.1 PROGRAMMING OF SET-POINT
  - 5.2 PROGRAMMING OF PARAMETERS
- 6 DESCRIPTION OF PARAMETERS
  - 6.1 PARAMETERS TABLE
- 7 TROUBLES, MAINTENANCE, GUARANTEE

#### 1 - GENERAL DESCRIPTION

TDF 12 is a digital microprocessor controller for Cooling applications with temperature control by ON/OFF control mode and with defrost control by stopping compressor mode. The process temperature value is visualised on 3 red displays and the output state and the defrost state are indicated by two led. The instrument has one output relay for compressor

and one input for PTC or NTC temperature probes. Furthermore it can be equipped with an internal buzzer to signalize the alarms and with a configurable digital input.

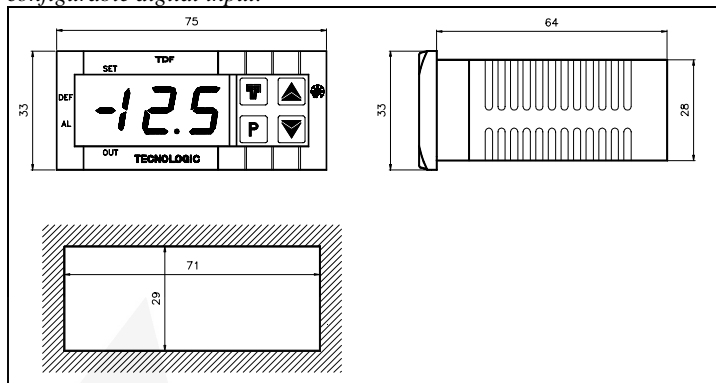

#### 1.1 - FRONT PANEL

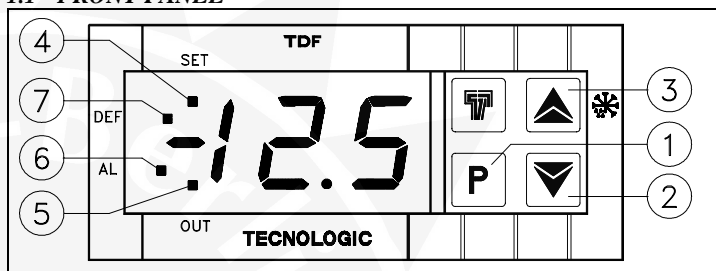

- 1 - Key P : Used for the set point setting and to program the functioning parameters
- 2 - Key DOWN : Used to decrease the values to be setted or to select parameters
- 3 - Key UP/DEFROST : Used to increase the values to be setted or to select parameters and to active manual defrost cycle
- 4 - Led SET : Signalize the set point programming mode (on) or the parameters programming mode (flashing)
- 5 - Led OUT : Signalize the on output state (on), off (off) or inhibited (flashing)
- 6 - Led AL : Signalize the on alarm state (on), off (off) or silenced (flashing)
- 7 - Led DEF : Signalize the on defrost state (on)

#### 1.2 - INSTRUMENT CODE

TDF 12 a b c dd

**a = SUPPLY**

F : 12 VAC/VDC

G : 24 VAC/VDC

C : 110 VAC

D : 230 VAC

**b = ALARM**

- : Alarm not present

B : Alarm present by internal Buzzer

**c = DIGITAL INPUT**

- : Digital Input not present

I : With Digital Input

**dd = SPECIAL CODES**

-- : Not extractable terminal block, input for PTC probes (KTY81-121)

E- : Extractable terminal block, input for PTC probes (KTY81-121)

-N : Not extractable terminal block, input for NTC probes (103AT-2)

EN : Extractable terminal block, input for NTC probes (103AT-2)

#### 2 - TECHNICAL DATA

##### ELECTRICAL DATA

**Supply:** 12, 24 VAC/VDC, 110, 230 VAC +/- 10%

**Frequency AC:** 50/60 Hz

**Power consumption:** 2 VA approx.

**Input/s:** 1 input for temperature probes PTC (KTY 81-121, 990  $\Omega$  at 25  $^{\circ}$ C) or NTC (103AT-2 10 K $\Omega$  at 25  $^{\circ}$ C); 1 digital input for free-voltage contacts.

**Output:** Relay (8A-AC1, 3A-AC3 250 VAC)

**Electrical life for relay output:** 100000 operat.

Protection class against electric shock: Class II for Front panel

Insulation: Reinforced insulation between the low voltage section (Supply 110 or 230 V and relay output) and the front panel; Reinforced insulation between the low voltage section (Supply 110 or 230 V and relay output) and the extra low voltage section ( inputs and supply 12 or 24 V); No insulation between supply 12 or 24 V and inputs.

#### MECHANICAL DATA

Housing: Self-extinguishing plastic, UL 94 V0

Dimensions: 33 x 75 mm DIN, depth 64 mm

Weight: 160 g approx.

Mounting: Flush in panel in 29 x 71 mm hole

Connections: 2,5 mm<sup>2</sup> screw terminal block

Degree of protection of front panel: IP 65 mounted in panel with gasket

Pollution situation: Normal

Operating temperature: 0 ... 55 °C

Operating humidity: 30 ... 95 RH% without condensation

Storage temperature: -10 ... +60 °C

#### FUNCTIONAL DATA

Temperature Control: ON/OFF

Defrost control: cycles by stopping compressor

Measurement range: PTC: -50...150 °C / -58 ... 199 °F; NTC: -50...50 °C / -58...122 °F

Display resolution: 1 ° in all range or 0.1 ° in range between -19.9 and 19.9

Overall accuracy: +/- 0,5 % fs

Sampling rate: 4 sample per second

Action: IC type according to EN 60730-1

Compliance: ECC directive EMC 89/336 (EN 50081-1, EN 50082-1), ECC directive LV 73/23 and 93/68 (EN 60730-1)

### 3 - INSTALLATION

**MECHANICAL MOUNTING:** The instrument, in case 33 x 75 mm, is designed for panel mounting. Make an hole 29 x 71 mm and insert the instrument, fixing it with the provided special bracket. We recommend to mount the gasket to obtain an IP 65 front protection. Avoid to place the instrument in areas with humidity or dirt. Connect the instrument as far as possible from source of electromagnetic disturbances so as motors, power relays, relays, electrovalves, etc.

**ELECTRICAL CONNECTIONS:** Carry out the electrical wiring connecting only one wire for each terminal, according to the following diagram, check that the power supply is the same as indicated on the instrument and the loads current is not upper than the maximum current admitted. The instrument, being a built in equipment with permanent connection into a cabinet, is not furnished with internal device protecting from overcurrent: it's recommended, therefore, to properly protect all the electric circuits connected to the instrument, with devices (ex. fuses) proportionate to the circulating currents. It's strongly recommended to use cables with proper insulation, according to the working voltages and temperatures. Furthermore, the input cables has to be kept separate from line voltage wiring. If the input cables is screened, it has to be connected on the ground with only one side. It is advisable to check that the parameters are those desired before connecting the outputs to the actuators so as to avoid malfunctioning. Whenever a failure of the instrument could cause dangerous or damaging situations, it should be kept in mind that the plant has to be provided with additional devices to ensure the safety. It's recommended to supply the instrument with supply 12 or 24 V using the Tecnologic TCTR transformer or equivalent type, and to use one transformer for each instrument.

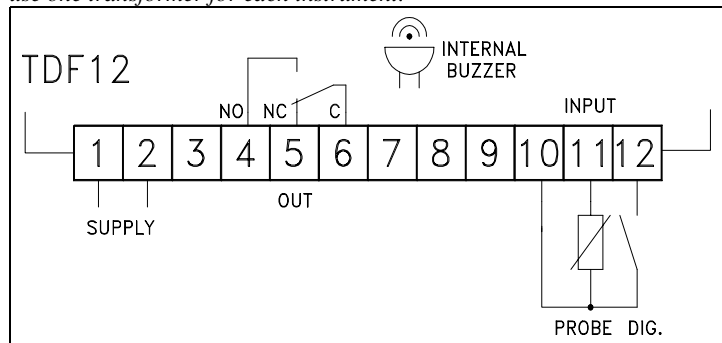

### 4 - OPERATING MODE

#### 4.1 - ON/OFF CONTROL

The temperature control mode of the instrument by ON/OFF mode occurs on the output according to the Set point fixed and to the differential switching point (par. "d") programmed. The regulator is intended for cooling applications, for this reason the programmable differential is always positive. The operating mode can be also modified by the "Compressor Protection" function, see the next chapter for this function.

#### 4.2 - COMPRESSOR PROTECTION FUNCTION

The function "Compressor Protection" is able, for cooling applications, to protect the compressor against "short cycles" by introducing a delay on the output activation. The parameters to be programmed for this function are:

"PS" : Protection type

- 1 - delay before start

- 2 - delay after stop

- 3 - delay between starts

"Pt" : Time delay setting for parameter "PS" (in min.)

The "Compressor Protection" function are automatically disconnected by setting "Pt" = 0.

#### 4.3 - DEFROST CONTROL

The automatic control of defrost, that is by stopping compressor, occurs according to this parameters:

"dC" : Defrost interval computation

- ct - based only on compressor running time (output on)

- rt - based on real time (instrument on)

"dI" : Interval between defrost cycles (in hrs)

"dE" : Length of defrost cycles (in min.)

#### 4.4 - MANUAL DEFROST

To active manual defrost cycle press key UP /DEFROST, when you are't in programming mode, and holding it down for about 5 seconds afterwhich the led DEF will be on and the instrument will start a defrost cycle. The manual or automatic defrost length is always programmable by par. "dE".

#### 4.5 - ALARM FUNCTIONS

The instrument can be equipped with an internal buzzer used as probe alarm signal, high and low temperature alarm or as external alarm trasmitted by the digital input (if present). The temperature alarm function works depending on the following parameters :

"HA" - High Alarm (relative to the Set Point)

"LA" - Low Alarm (relative to the Set Point)

"Ad" - Alarms (and fan) differential

"PA" - Alarm delay at power on (in hrs.)

"dA" - Alarm delay after defrost (in hrs.)

The alarm is operating at the end of the delays and will be on when the temperature goes upper than the value [Set +HA] or goes lower than the value [Set - LA]. The high and low temperature alarm can be disactivated setting the relative parameters "HA" or "LA" at 0. When the alarm is functioning to stop the buzzer push any of the programming key. In the mean time of the alarm signalation, although the buzzer is silenced, the instrument signalize the alarm through the AL led and it visualize, during the normal functioning:

- Alternatively "HI" and the temperature measure by the probe in case of high temperature alarm.

- Alternatively "LO" and the temperature measure by the probe in case of low temperature alarm.

- Alternatively "AL" and the temperature measure by the probe in case of external alarm.

#### 4.6 - DIGITAL INPUT

Furthermore the instrument can be equipped with a configurable digital input. The digital input works depending on the following parameters:

"FI" - Digital input function

0 - Not active

1 - End defrost: when the input intervenes during a defrost cycle the defrost ends and the defrost is inhibited

2 - Start defrost: when the input intervenes it's activated a defrost cycle. With the input signal activated the instrument is always in defrost state.

3 - External alarm signalation: when the input intervenes the internal buzzer (if present) is activated and the display shows alternatively "AL" and the temperature measured by the probe.

"LI" - Digital input logic mode

on - Contact normally opened: the programmed function of "FI" parameter works when the digital input contact is closed.

oF - Contact normally closed : the programmed function of "FI" parameter works when the digital input contact is opened.

## 5 - PROGRAMMING

### 5.1 - PROGRAMMING OF SET-POINT

Press key P then release it, led SET will flash and the SET value will be shown on display. To modify press key UP so as to increase value or DOWN so as to decrease it. These keys count one digit at a time but if the keys are pressed for over one second the value increases or decreases fast and after two seconds the speed increases even more, so as to reach the desired value immediately. The outgoing from the Set programming mode occurs automatically by not pressing any key for about 5 seconds, thus the temperature process value will again be displayed.

### 5.2 - PROGRAMMING OF PARAMETERS

To accede to the operating parameters it is necessary to press key P holding it down for about 5 seconds, after which the led SET will flash and the code of the first parameter will be visualized on the display. At this point key P can be released and by pressing UP or DOWN the desired parameter can be selected. Once the parameter on which we intended to operate has been selected to modify it press P, than released it, the set of the parameter will show up. To modify this value press UP or DOWN so as to increase or decrease the value. Once the desired value has been set press and than release P and the selected parameter code can be read on the display. By pressing UP or DOWN it is therefore possible to choose another one and modify it as previously mentioned. To outgoing from the programming mode no key is to be pressed for about 20 seconds, the instrument will automatically return to normal functioning mode, visualizing the temperature process value.

## 6 - DESCRIPTION OF PARAMETERS

Here following are described all the instrument parameters; pls. note that some of them could do not appear because are according to the kind of used instrument.

CC - FIXED PARAMETER

CA - CALIBRATION: Positive or negative offset which is calculated on probe reading before visualizing and to which the control functioning is also connected. This parameter can be utilized when a recalibration of the instrument is desired.

ru - UNIT OF MEASUREMENT: Determines the visualization of the temperature in Centigrade or Fahrenheit degree. It is to be remember that the change of this parameter modifies the visualization but not the Set and the Set limit ("LS" and "HS") programmed (eg. if the Set was 50°C and the unit changes, the Set will rest 50°F).

dP - DECIMAL POINT : Allows the insertion of the decimal point on the display and therefore to determine resolution of the reading value in the range from -19.9 to 19.9 (on= with decimal point, oF= without decimal point)

d - DIFFERENTIAL SWITCHING POINT: Value between starting and stopping of output OUT.

LS - MINIMUM SET: Minimum possible Set point value or lower limit of Set point .

HS - MAXIMUM SET: Maximum possible Set point value or higher limit of Set point.

rP - OUTPUT RELAY STATE IN CASE OF ERROR PROBE: Select output relay state in case of error probe (on = relay on, of = relay off).

dI - DEFROST INTERVAL: Automatic defrost frequency. This time is calculated based on the selection of par. "dC" and is intended in hrs.

dE - LENGHT OF DEFROST CYCLES: Determines the lenght of a manual or automatic defrost cycle and is intended in min..

dC - DEFROST INTERVAL COMPUTATION: Select the type of computation for defrost interval as based on total compressor running time (ct) or as based on real time instrument functioning (rt).

dL - DEFROST DISPLAY LOCK: Pemits the display visualization lock on the last temperature reading (on) during all the defrost cycle until, at the end of defrost, the temperature has not reached the value [Set + Et] (see par. "Et") or is ended the time setted on par. "dA". Or it permits the visualization of label "dF" (Lb) during the defrost cycle and, after the defrost, of label "Pd" until, at the end of defrost, the temperature has not reached the value [Set + Et] (see par. "Et") or is ended the time setted on par. "dA". The display will otherwise continue to visualize the temperature measured by the probe during the defrost cycle (oF).

Et - DIFFERENTIAL DISPLAY UNLOCK AFTER DEFROST : Temperature differential to unlock the display after the defrost. If it's utilized the option of "dL" parameter display lock during defrost, the display, after defrost will come back to visualize the temperature measured by the probe when it will be gone under the value [Set + Et].

PS - COMPRESSOR TYPE PROTECTION: Select the type of protection for the compressor against "short cycle". The possibles selections are:

1 = delay before start

2 = delay after stop

3 = delay between starts

Pt - TIME DELAY COMPRESSOR PROTECTION: Time delay setting for parameter "PS" intended in min.

od - OUTPUT DELAY AT POWER ON: Time delay of OUT relay activation after power on and expressed in min.

HA - HIGH ALARM: Temperature value in respect with Set point above at which the alarm will be on (The alarm will be on when the process temperature will be upper then the value Set + HA).

LA - LOW ALARM: Temperature value in respect with the Set point below at which the alarm will be on (The alarm will be on when the process temperature will be lower then the value Set - LA).

Ad - ALARM DIFFERENTIAL: Value between starting and stopping of alarm signal (par. HA and LA).

PA - ALARM DELAY AT POWER ON: Time delay after power on during which the alarm will not be activated (expressed in hrs).

dA - ALARM DELAY AND UNLOCK DISPLAY DELAY AFTER DEFROST : Time delay after a defrost cycle during which the alarm will not be activated and during which the display (see par. "dL") is locked (expressed in hrs).

FI - DIGITAL INPUT FUNCTION: It establish which function has to realize the digital input.

0 = No function

1 = End defrost

2 = Start defrost

3 = External alarm

LI - DIGITAL INPUT LOGIC MODE: It establish if the digital input causes the activation of the programmed function on par. "FI" when it's closed (on) or when it's opened (oF).

SP - SET POINT : Set point value

### 6.1 - PARAMETERS TABLE

Par.	Description	Range	Def.	Notes
CC	Fixed Parameter	-	-	
CA	Calibration	-15.0 .. +15.0 °C - °F	0.0	
ru	Unit of measurement	C - F	C	
dP	Decimal Point	on - oF	oF	
d	Differential switching point	0.0 ... 15.0 °C - °F	2.0	
LS	Minimum Set	-58 ... HS °C - °F	-50	
HS	Maximum Set	LS ... 199 °C - °F	150	
rP	Relay status in case of error probe	oF - on	oF	
dI	Defrost interval	0 ... 31 hrs	10	
dE	Lenght of defrost cycles	1 ... 99 min.	15	
dC	Defrost interval computation	ct - rt	rt	

<b>dL</b>	Defrost display lock	Lb - on - oF	oF	
<b>Et</b>	Differential display unlock after defrost	0 ... 20 °C - °F	2	
<b>PS</b>	Compressor type protection	1 - 2 - 3	1	
<b>Pt</b>	Time delay compressor protection	0 ... 31 min.	0	
<b>od</b>	Output delay at power on	0 ... 99 min.	0	
<b>HA</b>	High alarm	0 ... 50 °C - °F	10	
<b>LA</b>	Low alarm	0 ... 50 °C - °F	10	
<b>Ad</b>	Alarm differential	1 ... 31 °C - °F	1	
<b>PA</b>	Alarm delay at power on	0 ... 99 hrs.	2	
<b>dA</b>	Alarm delay and unlock display delay after defrost	0 ... 99 hrs.	1	
<b>FI</b>	Digital input function	0 - 1 - 2 - 3	0	
<b>LI</b>	Digital input logic mode	on - oF	on	
<b>SP</b>	Set Point	LS ... HS	0.0	

## 7 - PROBLEMS, MAINTENANCE AND WARRANTY

**ERRORS SIGNALLING:** The instrument shows the error message "--" , when the probe is interrupted or is in short-circuit and "uu" when is underrange or "oo" when is in overrange. In this cases verify the correct probe wiring with the instrument and afterward proceed to verify itself. Furthermore the instrument can visualize the error message of the internal memory "EE" , in this case verify, and if necessary, reprogram the functioning parameters.

**HOW TO CLEAN:** We recommend to avoid abrasive cleaners or containing solvents which could damage the instrument.

**WARRANTY AND REPAIRS:** The instrument is under warranty against construction vices or defected material, noticed within 12 months from delivery date. The warranty is limited to the repairs or to the substitution of the instrument. The eventual opening of the housing, the violation of the instrument or the wrong use and installation of the product means the automatically decay of the warranty. In case of defected instrument, noticed in warranty period or out of warranty, do contact our sales department to obtain the shipment authorisation. The defected product must be shipped to TECNOLOGIC with the detailed description of the failures found and without any fees or charge for Tecnologic, safe different agreements.