

Montageanleitung • Assembly Instructions • Notice de Montage

<http://www.kaelte-berlin.com/de/Viessmann>

Standregale • Shelving Systems • Rayonnage Standard

Alu • Aluminium • Aluminium

Kreuzstrebe • Crossbrace • Croisillon

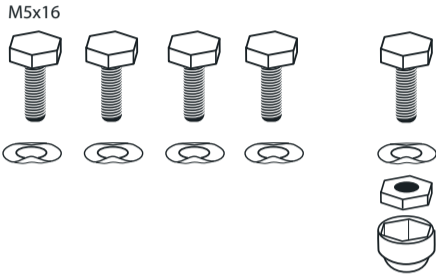

vormontiert für 1000 mm Felder
 premounted for section 1000 mm
 pré-monté pour un champ de 1000 mm

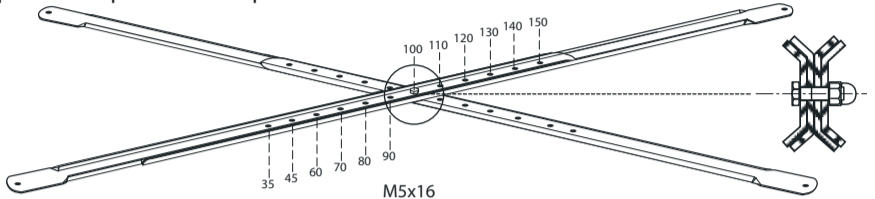

Strebe A = oben liegend
 Brace A = top
 Barre A = an-dessus

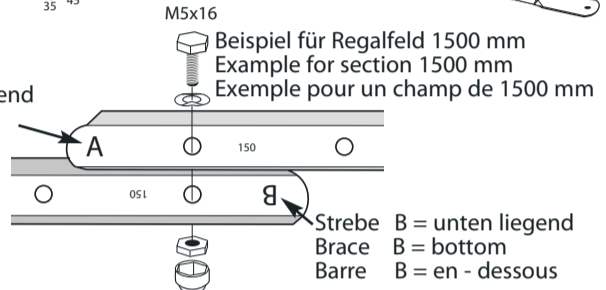

Strebe B = unten liegend
 Brace B = bottom
 Barre B = en-dessous

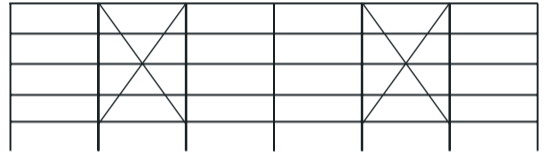
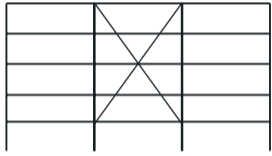
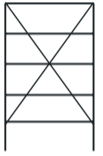

Montage • Assembly • Montage

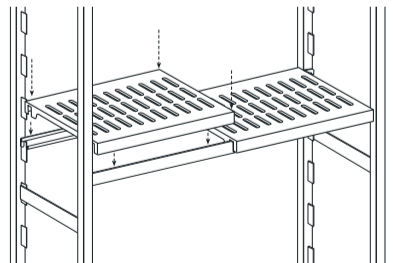
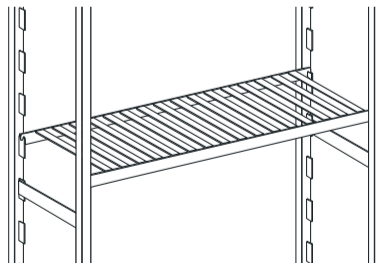
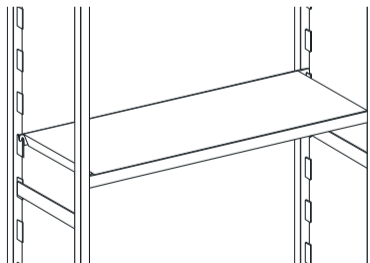
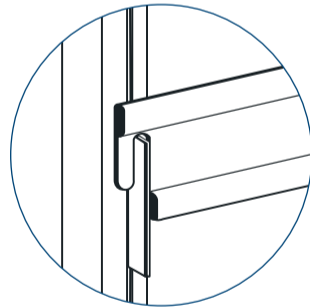
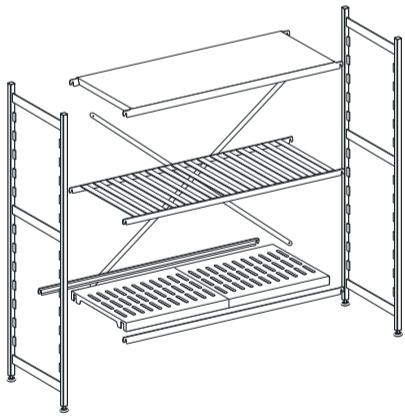
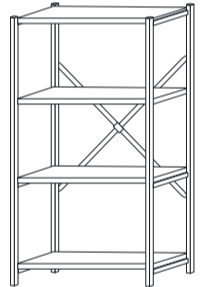
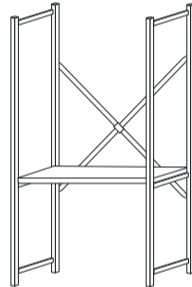
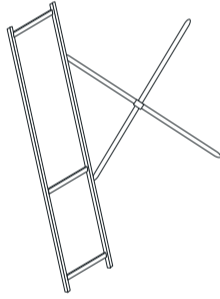
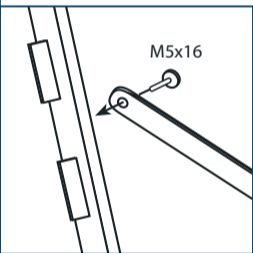

Montage Rücken-an-Rücken • Assembly back-to-back • Dos

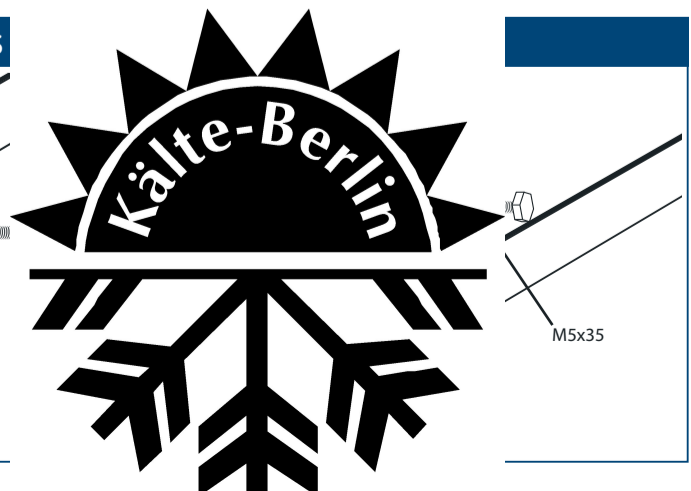
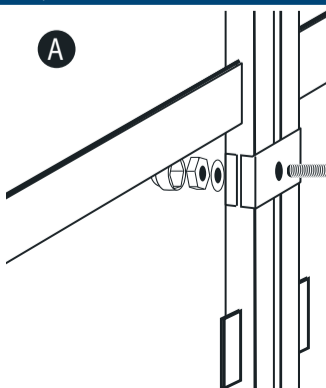
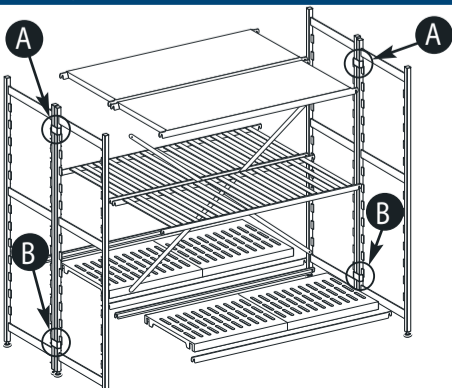

Eckbau • Shelf hooks • Montage en Angle

Geschlossene Auflagen • solid shelves • tablettes pleines

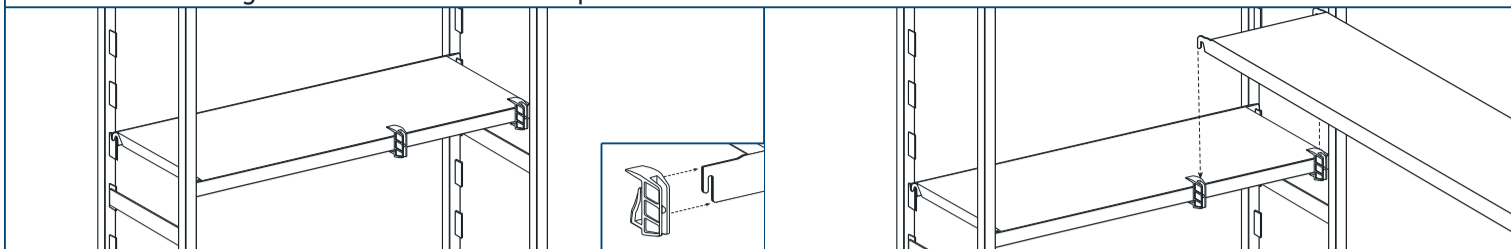

Rostauflagen • slatted shelves • clayettes

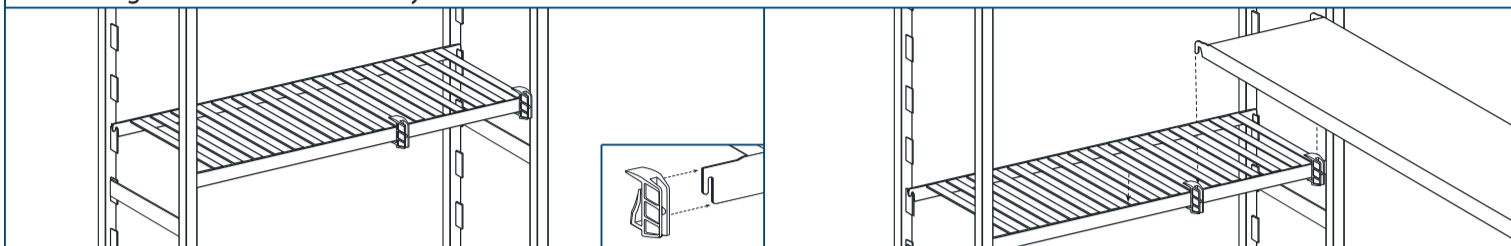

Geschlossene Kunststoff-Auflagen • solid polymer shelves • tablettes pleines en polystyrol

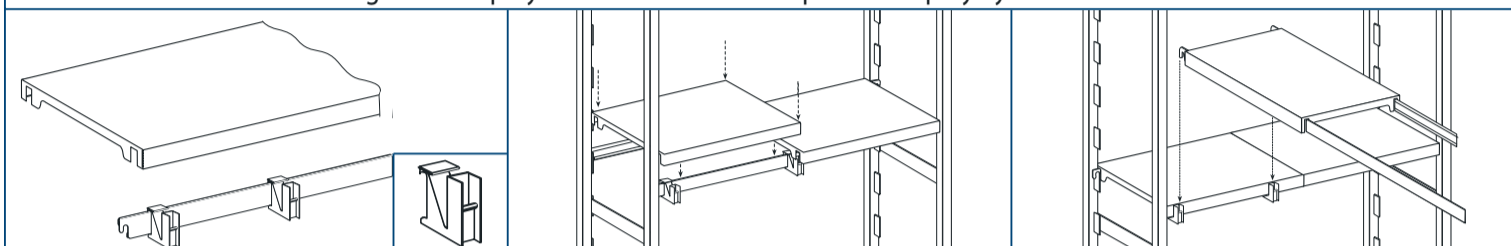

Kunststoffroste • polymer louvred shelves • tablettes ajourées en polystyrol

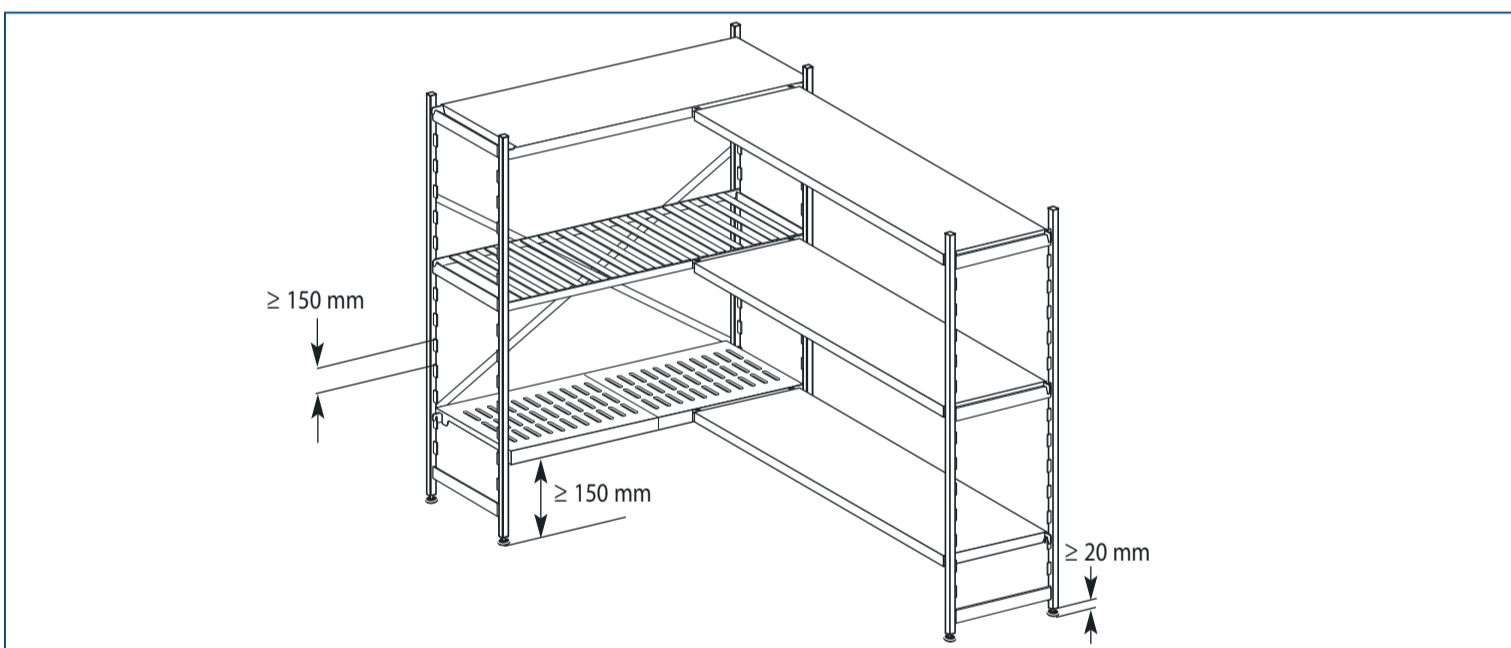
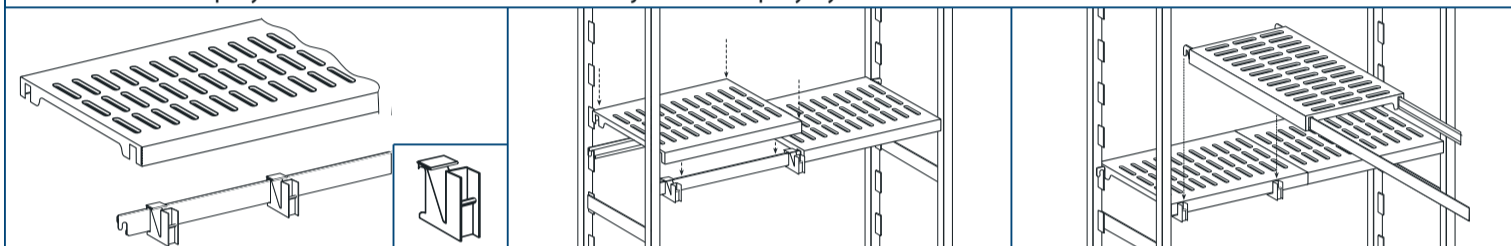









Reinigungshinweise • cleaning instructions • indications de nettoyage

Abrasive und chlorhaltige Reinigungsmittel sind nicht erlaubt. Die Regale sind regelmäßig mit einem feuchten Lappen abzuwischen. Das unterste Bord muß mindestens 150 mm Bodenfreiheit gewährleisten. ● Abrasive and corrosive agents are not allowed. The shelvings must be cleaned regularly with a damp cloth. The minimum distance between the floor and the lowest shelf is 150 mm ● Produits lessiviels à exclure (produits chlorés et abrasifs). À nettoyer périodiquement avec port de gants. Le premier niveau doit être à 150 mm minimum du sol.

Die französische Norm NF für Lebensmittelhygiene bescheinigt, daß das Produkt den Anforderungen der NF 031 genügt (Reinigungsmöglichkeit). Zertifiziert von AFNOR CERTIFICATION, 11 Avenue Francis de Préssensé 93571 St. Denis la Plaine Cedex, France. ● The french standard NF for food hygiene confirms the correspondance to the NF 031 (cleaning ability). Certified by AFNOR CERTIFICATION, 11 Avenue Francis de Préssensé 93571 St. Denis la Plaine Cedex, France. ● La marque NF Hygiène alimentaire certifie la conformité au référentiel NF 031 (aptitudes au nettoyage). Organisme certificateur: AFNOR CERTIFICATION, 11 Avenue Francis de Préssensé 93571 St. Denis la Plaine Cedex, France.

Lasten und Prüfzeichen • Loads and certification marks • Charges et marques de conformités

Feldlast • section load • charge per champ	Norm(e) 20	Norm(e) 12
600 kg	  	  
1200 kg	  	—
2000 kg	—	—

Viessmann Kältetechnik AG
Schleizer Straße 100
95030 Hof/Saale
Germany

Telefon 0 92 81/ 81 4-0
Telefax 0 92 81/ 81 4-2 69

info@vkag.de
www.vkag.de

 **VISSMANN**