

Sè\ç\Ö\!|ã
Ö\ç\Á\æ\!Á\F
FGGEJ\Ö\!|ã
Ö\ç\Á\æ\!Á\F
Ö\ç\Á\æ\!Á\F
Tæ\!|Ö\æ\ç\è\!|ã\è\^
Q\ç\!^ç\ , Èæ\ç\è\!|ã\è\ç\{

No.	F003-3094
ISSUED:	MAY. 7, 2008
REVISED:	NOV. 5, 2010
SERVICE INFORMATION	
:	----



**HOSHIZAKI
CRESCENT CUBER**

MODEL KM-125A

PARTS LIST

(GENERAL, CHINA, OCEANIA, UK, CONT)

- T-1 MAY 2008
- T-2 DEC. 2008
- U-1 FEB. 2009
- V-1 APR. 2010
- V-3 NOV. 2010

AUXILIARY CODE

U - 1

The auxiliary code is the first two characters in the serial number. The first character indicates the production year. Years progress or regress in alphabetical order. The series of letters and skipped letters depend on UL listing, production, and model. See the auxiliary code(s) and corresponding year(s) on the front cover.

The second character indicates significant part changes within the same year. Base is "1" and this number advances for each change. If there is no significant part change at the turn of the year, this number starts from "0."

MARKS LOCATED UNDER THE AUXILIARY CODE

- = Part deleted.
- x = Part deleted and replaced by "o" part.
- o = New part in place of "x" part.

FASTENER PART NUMBER

SCREWS

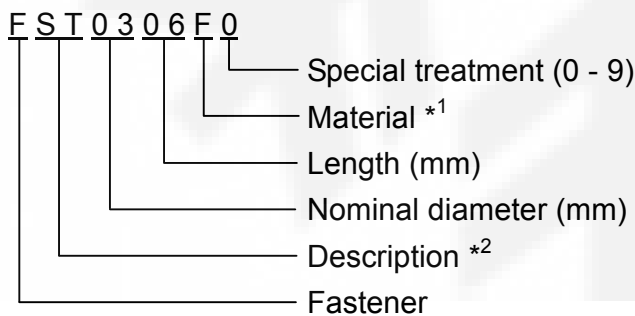

*1 **Material**

- F: Steel
- S: Austenitic stainless steel
- M: Martensitic stainless steel
- B: Copper alloy
- P: Polycarbonate
- N: Polyamide
- V: PVC
- A: ABS
- X: Polyacetal
- L: Aluminum

NUTS & WASHERS

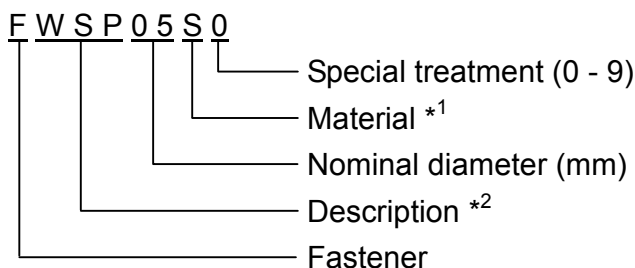

*2 **Description**

- First letter
- S: Machine screw
- T: Tapping screw
- M: Wood screw
- B: Bolt
- W: Washer
- N: Nut

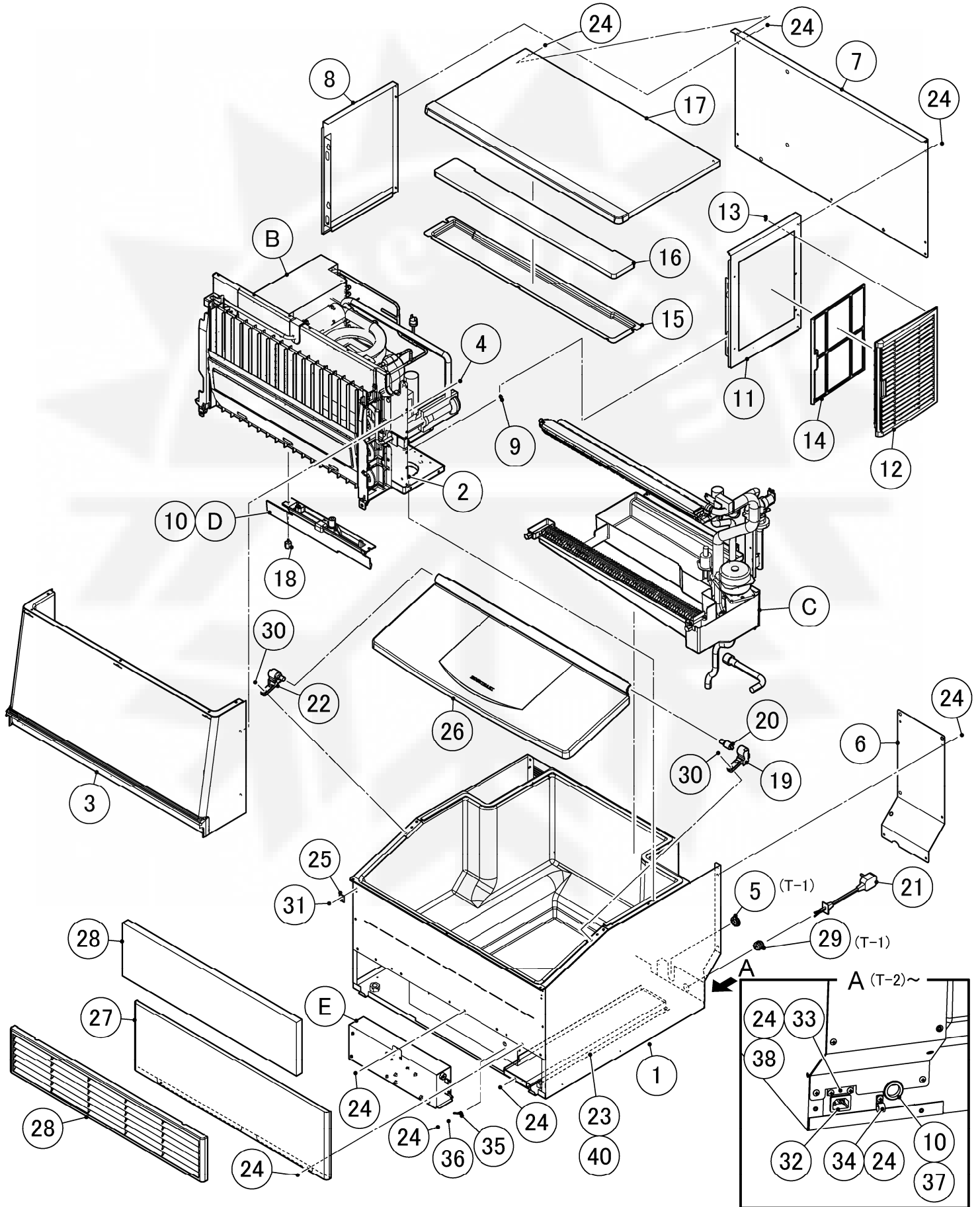

GENERAL, CHINA, OCEANIA, UK, CONT

MODEL: KM-125A		TITLE: A. ICE CUBER ASSY						
INDEX NO.	DESCRIPTION	MATERIAL OR MODEL NUMBER	PART NUMBER	REQ'D NUMBER				
				T-1	T-2 U-0	U-1 V-0	V-1 V-2	V-3
B	REFRIGERATION CIRCUIT		118966A01	1	1	1	1	1
C	WATER CIRCUIT		118967A01	1	1	1	-	-
			120486A01				1	1
D	MECHANICAL BIN SWITCH - 30		371417A01	1	1	1	1	1
E	CONTROL BOX ASSY		371208A01	1	1	-	-	-
		CHINA	371208A01			1	1	1
		OCEANIA,UK,CONT	371208A03			1	1	1
F	LOUVER ASSY - 30		371295A01	1	1	1	1	1
G	LABEL LOCATION	GENERAL, OCEANIA, UK, CONT	255427A01	1	1	1	1	1
		CHINA	255427A02	1	1	1	1	1
H	ACCESSORIES		A01503-01	1	1	1	1	1
1	BIN ASSY - 30		118990G03	1	1	1	1	1
2	TRUSS HEAD SCREW	SUS 4x30	FST0430S0	4	4	5	5	5
3	FRONT COVER - 30		254938G01	1	1	1	1	1
4	TRUSS HEAD SCREW	SUS 4x20	FST0420S0	4	4	4	4	4
5	BUSHING		471031R01	1	-	-	-	-
6	REAR COVER		371199M01	1	1	1	1	1
7	REAR PANEL (UP) - 30		371000M01	1	1	1	1	1
8	SIDE PANEL (L,UP)		371013G01	1	1	1	1	1
9	TAPER COLLAR		4H0171-01	4	4	4	4	4
10	GROMMET		410466-14		1	-	-	-
11	SIDE PANEL (R,UP)		371015G01	1	1	1	1	1
12	LOUVER B		1A0548-01	1	1	1	1	1
13	PUSH RETAINER	94807A024	4A2414-01	3	3	3	3	3
14	AIR FILTER B		2A2063G01	1	1	1	1	1
15	TOP COVER - 30		254953P01	1	1	1	1	1
16	INSULATION - UP,30		472444P01	1	1	1	1	1
17	TOP PANEL - 30		371008G01	1	1	1	1	1
18	THUMBSCREW		415949G12	2	2	2	2	2
19	HINGE MOUNT (R)		370969P01	1	1	1	1	1
20	HINGE	FYN-P1-R103	P01080-01	1	1	1	1	1

GENERAL, CHINA, OCEANIA, UK, CONT

MODEL: KM-125A		TITLE: A. ICE CUBER ASSY						
INDEX NO.	DESCRIPTION	MATERIAL OR MODEL NUMBER	PART NUMBER	REQ'D NUMBER				
				T-1	T-2 U-0	U-1 V-0	V-1 V-2	V-3
21	POWER SUPPLY CODE	GENERAL	P00048-01	1	-	-	-	-
		CHINA	4Y1082-01	1	-	-	-	-
		CHINA	P01960-01		1	1	1	1
		OCEANIA	P00242-01		1	1	1	1
		UK	P00241-01		1	1	1	1
		CONT	P00240-01		1	1	1	1
22	HINGE MOUNT (L)		370970P01	1	1	1	1	1
23	WIRE COVER		371197M01	1	1	-	-	-
24	TRUSS HEAD SCREW	4x8	FST0408F0	24	29	29	29	29
25	CLAMP		472587M01	2	2	2	2	2
26	DOOR ASSY		370980G01	1	1	1	1	1
27	FRONT PANEL (LO)		255033M02	1	1	1	1	1
28	INSULATION (F) - 30		472742P01	1	1	1	1	1
29	BUSHING	SR-7K-2	420472-02	1	-	-	-	-
30	PAN HEAD SCREW (S)	SUS 5x16	FSS0516S0	4	4	4	4	4
31	TRUSS HEAD TAPPING SCREW (TYPE B)	4x8	FT20408F0	2	2	2	2	2
32	CONNECTOR		P00245-02		1	1	1	1
33	WIRE COVER (B)		473272M01		1	-	-	-
34	NYLON CLAMP	NK-6N	418814-06		1	1	1	1
35	WIRE HARNESS		255429Z01	1	1	1	1	1
36	SPRING WASHER		FWSP04F0		1	1	1	1
37	BUSHING	OCB-875	428394-04			1	1	1
38	WIRE COVER(B)		473820M01			1	1	1
40	WIRE COVER		372564M01			1	1	1

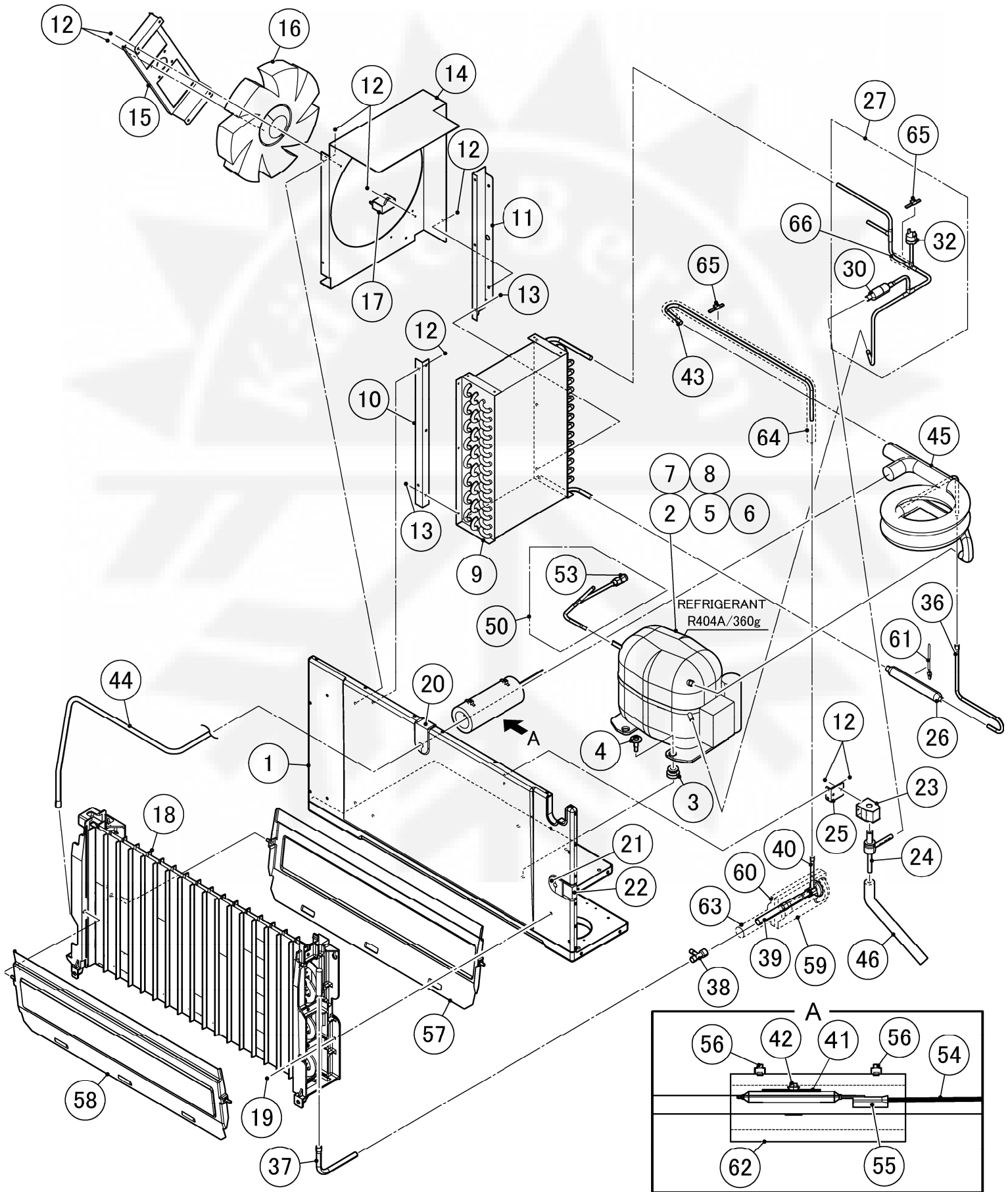

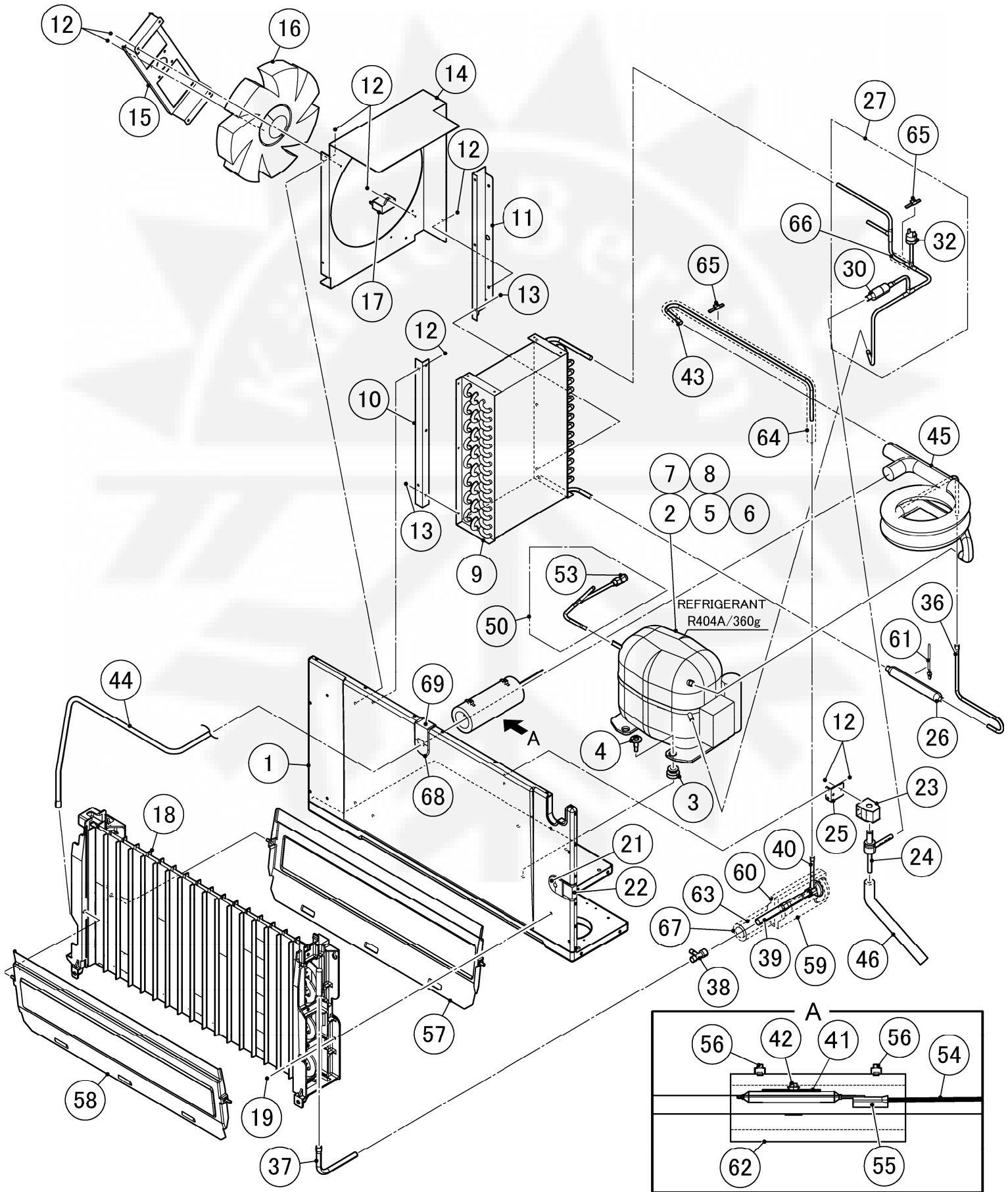

GENERAL, CHINA, OCEANIA, UK, CONT

MODEL: KM-125A		TITLE: B. REFRIGERATION CIRCUIT						
INDEX NO.	DESCRIPTION	MATERIAL OR MODEL NUMBER	PART NUMBER	REQ'D NUMBER				
				T-1	T-2 U-0	U-1 V-0	V-1 V-2	V-3
1	BASE ASSY		371180G01	1	1	1	-	-
			373776G01				1	1
2	COMPRESSOR	SC12DL 230V 50Hz	P01018-01	1	1	1	1	1
3	GROMMET		450897-01	4	4	4	4	4
4	BOLT		468180-01	3	4	4	4	4
5	STARTING RELAY		452237-01	1	1	1	1	1
6	COVER		459924-01	1	1	1	1	1
7	STARTING CAPACITOR		456350-01	1	1	1	1	1
8	CORD RELIEF		452239-01	1	1	1	1	1
9	CONDENSER		P00822-01	1	1	1	1	1
10	BRACKET (A) - CONDENSER		472458M01	1	1	1	1	1
11	BRACKET (B) - CONDENSER		472463M01	1	1	1	1	1
12	TRUSS HEAD SCREW	4X8	FST0408F0	17	21	21	21	21
13	T2 SCREW	4X8	FT20408F0	6	6	6	6	6
14	SHROUD - 30		255381M01	1	1	1	1	1
15	BRACKET - FAN MOTOR		371200M01	1	1	1	1	1
16	FAN MOTOR	A4E250-AH02-01	P00824-01	1	1	1	1	1
17	CAPACITOR		P00849-01	1	1	1	1	1
18	EVAPORATOR ASSY		371296G01	1	1	1	-	-
			373810G01				1	1
19	TRUSS HEAD SCREW	SUS 4X12	FST0412S0	4	4	4	4	4
20	GROMMET (A)		472435R01	1	1	1	-	-
21	GROMMET (C1)		472437R01	1	1	1	1	1
22	GROMMET (C2)		472560R01	1	1	1	1	1
23	COIL - VALVE	AMS-C23HD-2	P00810-01	1	1	1	1	1
24	VALVE BODY	ATS-B7SHDU-2	4A3978-01	1	1	1	1	1
25	BRACKET - HOT GAS		472590M01	1	1	1	1	1
26	DRIER		P00026-01	1	1	1	1	1
27	COPPER TUBE (A) - H		371212G01	1	1	1	1	1
30	STRAINER	COPPER TUBE (A) - H 371212G01	P00812-01	1	1	1	1	1
32	PRESSURE SWITCH	COPPER TUBE (A) - H 371212G01 ACB-1UB44	463180-04	1	1	1	1	1

GENERAL, CHINA, OCEANIA, UK, CONT

MODEL: KM-125A		TITLE: B. REFRIGERATION CIRCUIT						
INDEX NO.	DESCRIPTION	MATERIAL OR MODEL NUMBER	PART NUMBER	REQ'D NUMBER				
				T-1	T-2 U-0	U-1 V-0	V-1 V-2	V-3
36	COPPER TUBE (B) - H		472595M01	1	1	1	1	1
37	COPPER TUBE (B) - L		472597M01	1	1	1	-	-
			474848M01	-	-	-	1	1
38	TEE	111R-642	436000-08	1	1	1	1	1
39	COPPER TUBE (A) - L		472596M01	1	1	1	1	1
40	EXP. VALVE	HFE-10NHD-6	P00826-01	1	1	1	1	1
41	HOLDER - EXPV		451267-01	1	1	1	1	1
42	CLAMP		443461-02	1	-	-	-	-
			443461-01		1	1	1	1
43	COPPER TUBE (C) - H		371213M01	1	1	1	1	1
44	COPPER TUBE (C) - L		371215M01	1	1	1	-	-
			374282M01				1	1
45	HEAT EXCHANGER		255315G01	1	1	1	1	1
46	COPPER TUBE - HOT GAS		371216G01	1	1	1	1	1
50	COPPER TUBE - ACCESS VALVE		472598G01	1	1	1	1	1
53	ACCESS VALVE	COPPER TUBE - ACCESS VALVE 472598G01 TCJ-2F20NH DU-1	457729-01	1	1	1	1	1
54	THERMISTOR		P00027-01	1	1	1	1	1
55	HOLDER - THERMISTOR		436455-01	1	1	1	1	1
56	TIE		7920-0010	2	2	2	2	2
57	SEPARATOR - 30		370971G03	1	1	1	1	1
58	SEPARATOR - 30		370971G04	1	1	1	1	1
59	COVER (A) - EXP. VALVE		324313-01	1	1	1	1	1
60	COVER (B) - EXP. VALVE		324313-02	1	1	1	1	1
61	PUSH MOUNT TIE	T30RSF	436156-01		1	1	1	1
62	INSULATION TUBE	7762-3858 L=150	H73858150	1	1	1	1	1
63	INSULATION TUBE		H71323140	1	1	1	1	1
64	INSULATION TUBE		H70717640	1	1	1	1	1
65	TIE		7920-0003		2	2	6	6
66	INSULATION TUBE		H71020050		1	1	1	1
67	INSULATION TUBE		H72030100				1	1

GENERAL, CHINA, OCEANIA, UK, CONT

MODEL: KM-125A		TITLE: B. REFRIGERATION CIRCUIT						
INDEX NO.	DESCRIPTION	MATERIAL OR MODEL NUMBER	PART NUMBER	REQ'D NUMBER				
				T-1	T-2 U-0	U-1 V-0	V-1 V-2	V-3
68	GROMMET(A1)		475110R01				1	1
69	GROMMET(A2)		475111R01				1	1

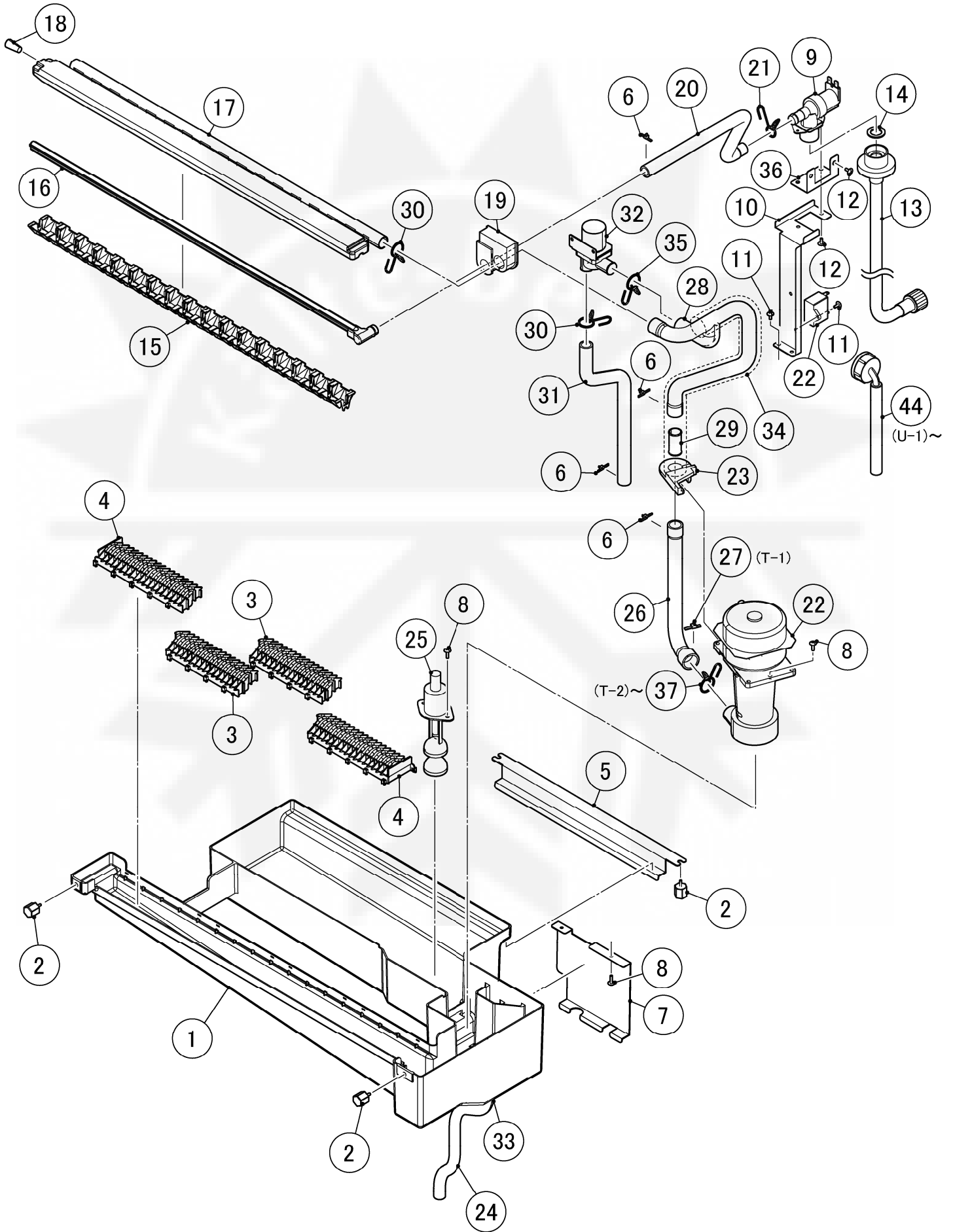

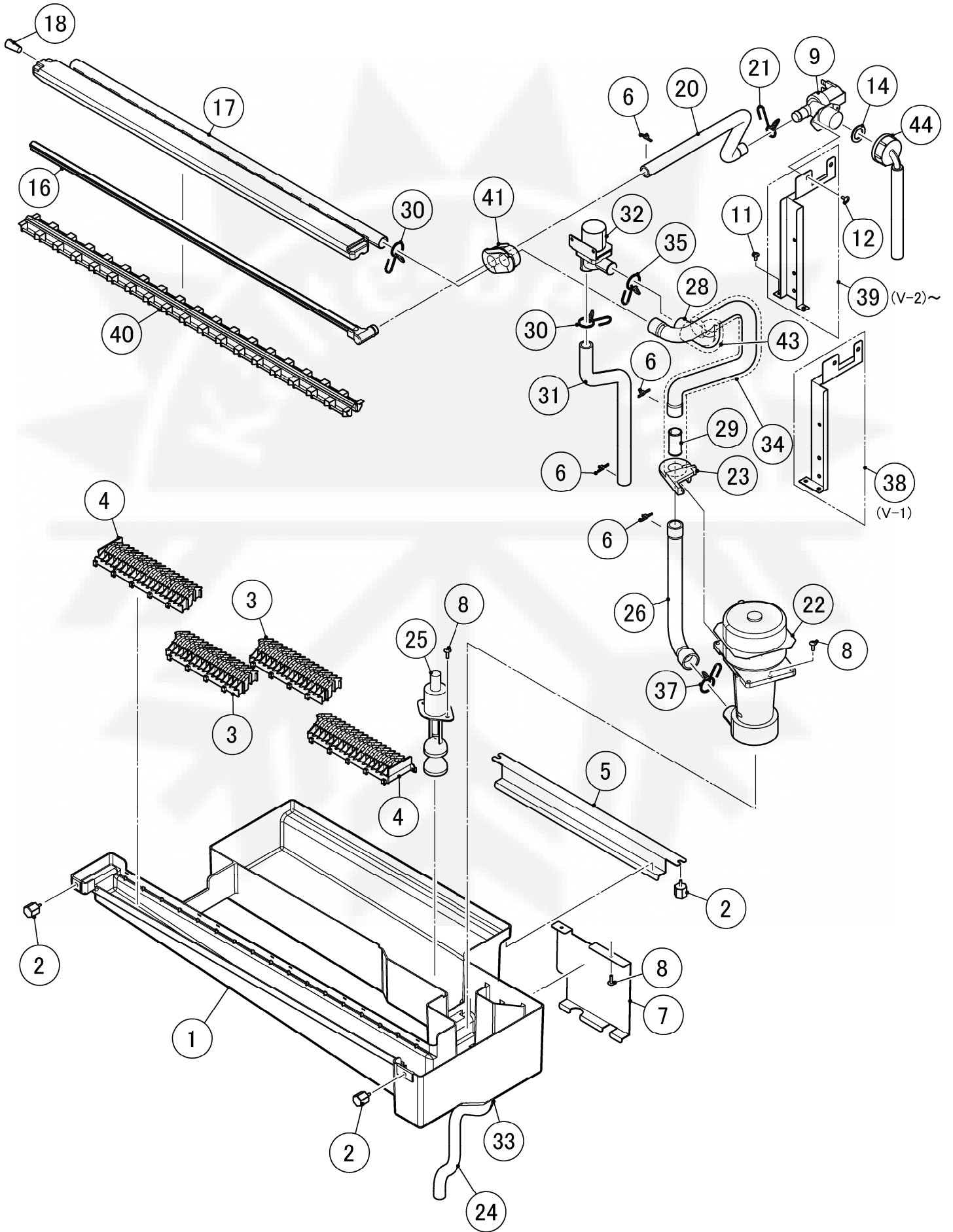

GENERAL, CHINA, OCEANIA, UK, CONT

MODEL: KM-125A		TITLE: C. WATER CIRCUIT						
INDEX NO.	DESCRIPTION	MATERIAL OR MODEL NUMBER	PART NUMBER	REQ'D NUMBER				
				T-1	T-2 U-0	U-1 V-0	V-1 V-2	V-3
1	TANK - 30		118840P01	1	1	1	1	1
2	THUMBSCREW		415949G12	4	4	4	4	4
3	CUBE GUIDE (B)		2A3363-01	2	2	2	2	2
4	CUBE GUIDE (A)		2A3362-01	2	2	2	-	-
			258598P01				2	2
5	HOOK (B) - TANK		371193M01	1	1	1	1	1
6	TIE		7920-0002	4	4	4	4	4
7	HOOK (D) - TANK		371204M01	1	1	1	1	1
8	TRUSS HEAD SCREW	SUS 4x12	FST0412S0	6	6	6	6	6
9	WATER VALVE	2L/min	P01031-01	1	1	1	1	1
10	BRACKET (A) - WATER VALVE		371011M01	1	1	1	-	-
11	TRUSS HEAD SCREW	4x8	FST0408F0	5	5	5	5	5
12	TRUSS HEAD SCREW	SUS 4x8	FST0408S0	2	4	4	2	2
13	HOSE	L=2500	462060-04	1	1	-	-	-
14	RUBBER GASKET		413854-03	1	1	1	1	1
15	SPRAY GUIDE		118939P01	1	1	1	-	-
16	WATER SUPPLY TUBE - 30		254949P01	1	1	1	1	1
17	SPRAY TUBE - 30		254950P01	1	1	1	1	1
18	PLUG		4A0176-01	1	1	1	1	1
19	GROMMET (B)		472436R01	1	1	1	-	-
20	WATER SUPPLY PIPE (D)		472440R01	1	1	1	1	1
21	HOSE CLAMP		427443-07	1	1	1	2	2
22	PUMP MOTOR	PV-0512AHZ1	P00825-01	1	1	1	1	1
23	COVER - PUMP MOTOR		371173R01	1	1	1	1	1
24	DRAIN PIPE (B)		472442P01	1	1	1	1	1
25	FLOAT SWITCH	OLV-29Z-2P2	P00816-01	1	1	1	1	1
26	WATER SUPPLY PIPE (H)		472572R01	1	1	1	-	-
			474937R01				1	1
27	TIE	CV-150	7920-0003	1	-	-	10	10
28	WATER SUPPLY PIPE (C)		255397R01	1	1	1	1	1
29	SOCKET		472564P01	1	1	1	1	1
30	HOSE CLAMP		427443-05	2	2	2	1	1

GENERAL, CHINA, OCEANIA, UK, CONT

MODEL: KM-125A		TITLE: C. WATER CIRCUIT						
INDEX NO.	DESCRIPTION	MATERIAL OR MODEL NUMBER	PART NUMBER	REQ'D NUMBER				
				T-1	T-2 U-0	U-1 V-0	V-1 V-2	V-3
31	DRAIN PIPE		472441R01	1	1	1	-	-
			472441R02				1	1
32	SOLENOID VALVE		P00018-01	1	1	1	1	1
33	SILICON HOSE	φ14xφ18xL30	H11418030	1	1	1	1	1
34	INSULATION TUBE		H72030480	1	1	1	1	1
35	HOSE CLAMP		427443-06	1	1	1	2	2
36	BRACKET(B) - WATER VALVE		472772M01	1	1	1	-	-
37	HOSE CLAMP		427443-03		1	1	1	1
38	BRACKET(A) - WATER VALVE		373978M01				1	-
39	BRACKET(A) - WATER VALVE		374255M01				-	1
40	SPRAY GUIDE		258313P07				1	1
41	GROMMET		474786R01				1	1
42	TIE	CV-100	7920-0002		3	3	3	3
43	INSULATION TUBE		H72030090				1	1
44	HOSE	XG-1	P01401-01			1	1	1

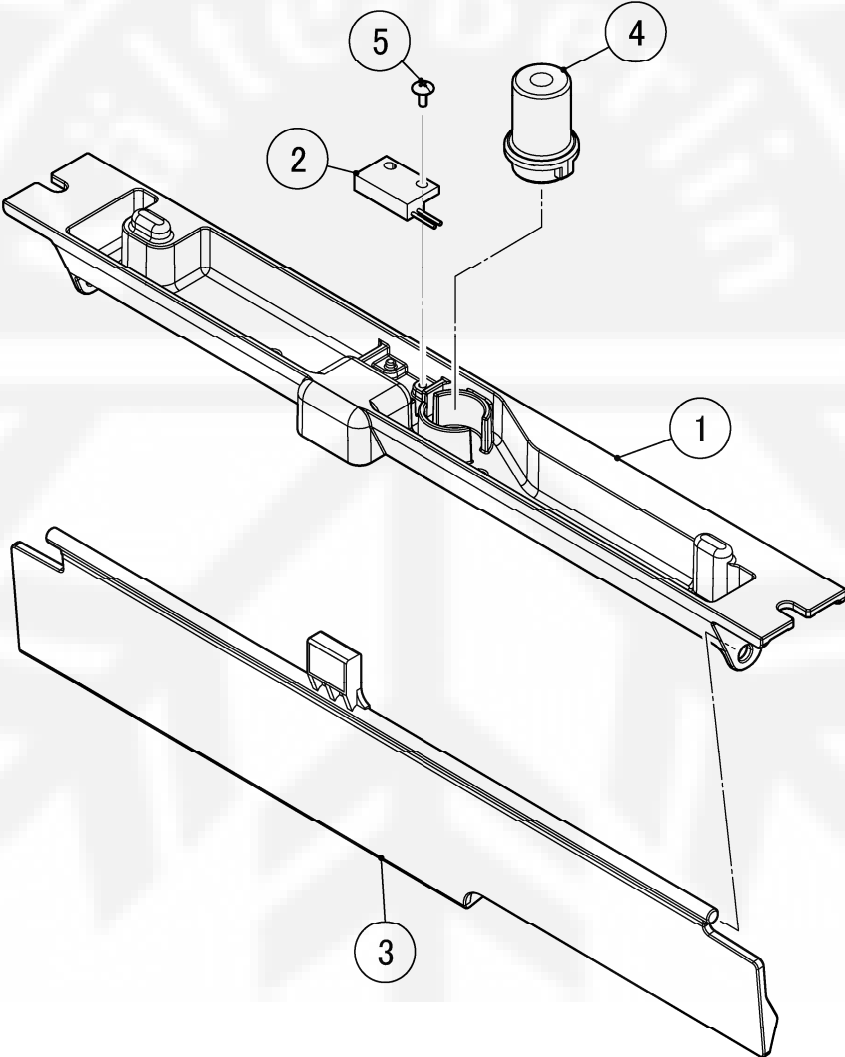

GENERAL, CHINA, OCEANIA, UK, CONT

MODEL: KM-125A					TITLE: D. MECHANICAL BIN SWITCH				
INDEX NO.	DESCRIPTION	MATERIAL OR MODEL NUMBER	PART NUMBER	REQ'D NUMBER					
				T-1	T-2 U-0	U-1 V-0	V-1 V-2	V-3	
1	ACTUATOR BASE		118845P01	1	1	1	1	1	
2	REED SWITCH		431788-02	1	1	1	1	1	
3	ACTUATOR - 30		371416G01	1	1	1	1	1	
4	GROMMET (E)		472446R01	1	1	1	1	1	
5	T2 SCREW	SUS 3X8	FT50308M0	1	1	1	1	1	

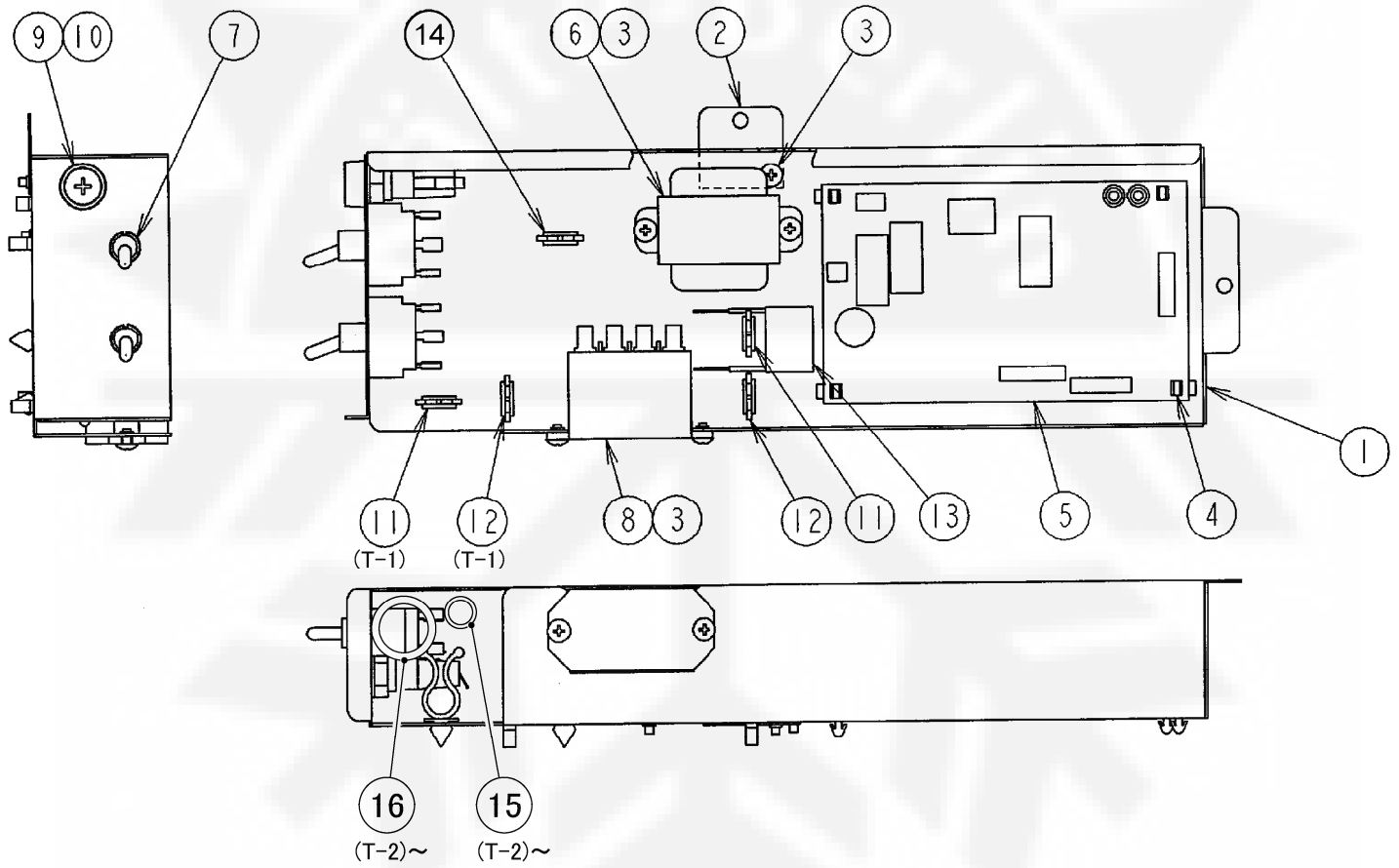

GENERAL, CHINA, OCEANIA, UK, CONT

MODEL: KM-125A		TITLE: E. CONTROL BOX ASSY						
INDEX NO.	DESCRIPTION	MATERIAL OR MODEL NUMBER	PART NUMBER	REQ'D NUMBER				
				T-1	T-2 U-0	U-1 V-0	V-1 V-2	V-3
1	CONTROL BOX		118864M01	1	1	-	-	-
		CHINA	118864M01			1	1	1
		OCEANIA,UK,CONT	118864M02			1	1	1
2	BRACKET - CONTROL BOX		472575M01	1	1	1	1	1
3	TRUSS HEAD SCREW	4x6	FST0406F0	5	5	5	5	5
4	BOARD SUPPORT		468879-01	4	4	4	4	4
5	CONTROLLER BOARD	HS2006071	P00013-02	1	1	1	-	-
		HKM2006V003	P01771-02				1	1
6	TRANSFORMER	DB48-26	P00012-01	1	1	1	1	1
7	TOGGLE SWITCH	KND203	P00033-01	2	2	-	-	-
		CHINA	P00033-01			2	2	2
		OCEANIA,UK,CONT	P01206-01			2	2	2
8	POWER RELAY	G7L-1A-TUB	P00034-01	1	1	1	1	1
9	FUSE HOLDER	BF115	P00014-01	1	1	-	-	-
		CHINA	P00014-01			1	1	1
		OCEANIA,UK,CONT	P01397-01			1	1	1
10	FUSE	125/250V 5A	P00015-01	1	1	1	1	1
11	CLAMP	No.249	427902-03	3	1	1	1	1
12	CLAMP	No.248	427902-04	2	1	1	1	1
13	CAPACITOR	REB474	P00228-01	1	1	1	1	1
14	CLAMP	No.4253	427902-05		1	1	1	1
15	BUSHING	OCB-500	428394-02		1	1	1	1
16	BUSHING	OCB-1000	428394-05		1	1	1	1

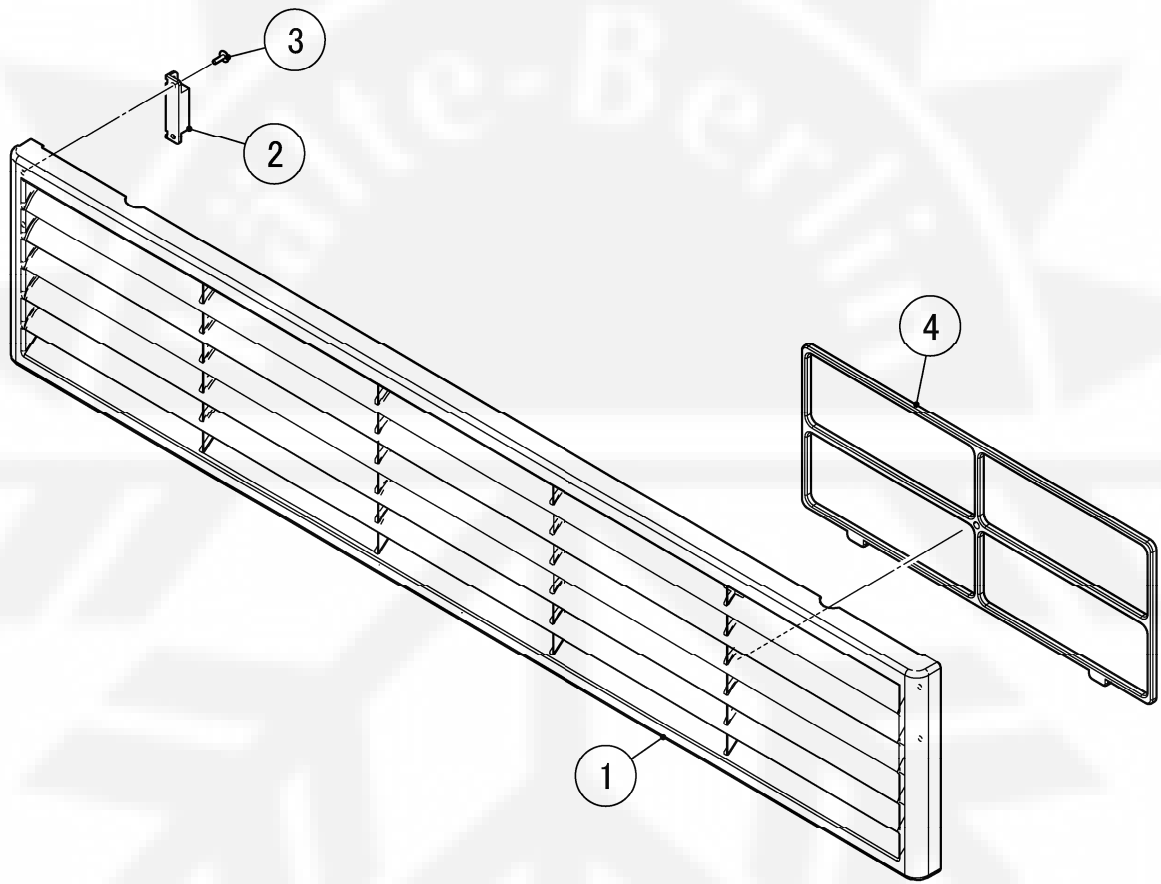

GENERAL, CHINA, OCEANIA, UK, CONT

MODEL: KM-125A		TITLE: F. LOUVER ASSY - 30						
INDEX NO.	DESCRIPTION	MATERIAL OR MODEL NUMBER	PART NUMBER	REQ'D NUMBER				
				T-1	T-2 U-0	U-1 V-0	V-1 V-2	V-3
1	LOUVER - 30		118899P01	1	1	1	1	1
2	MAGNET CATCH	MC-110NF-GR	P01032-01	2	2	2	2	2
3	TRUSS HEAD SCREW	SUS 3x8	FT20308M0	4	4	4	4	4
4	AIR FILTER		371154G01	1	1	1	1	1

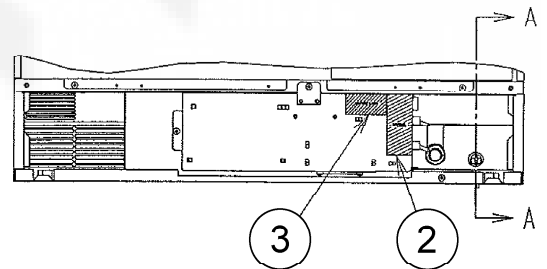
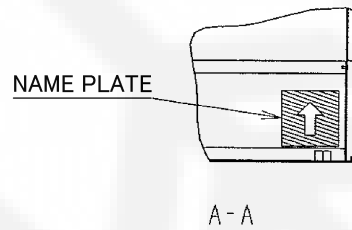
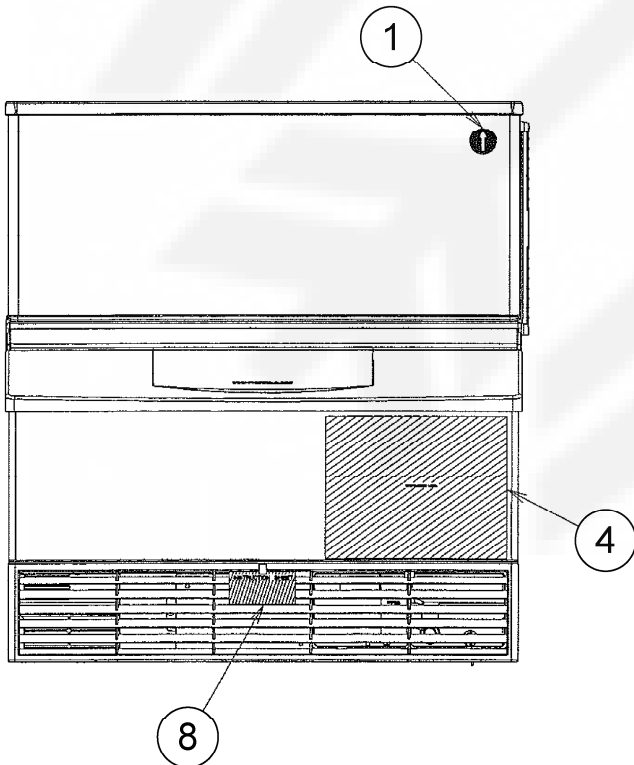
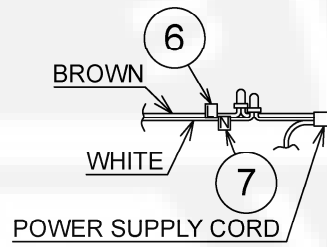
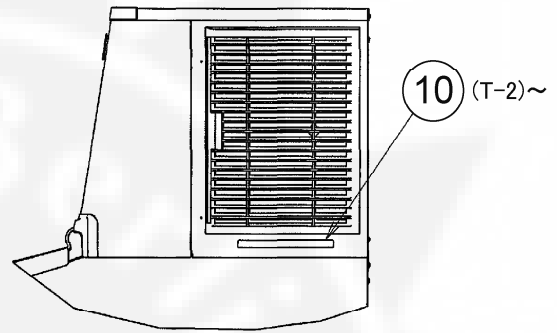
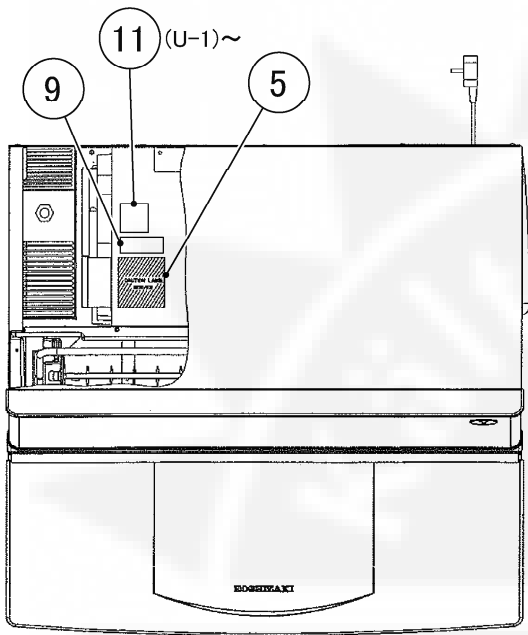

GENERAL, CHINA, OCEANIA, UK, CONT

MODEL: KM-125A		TITLE: G. LABEL LOCATION						
INDEX NO.	DESCRIPTION	MATERIAL OR MODEL NUMBER	PART NUMBER	REQ'D NUMBER				
				T-1	T-2 U-0	U-1 V-0	V-1 V-2	V-3
1	LABEL - PENGUIN		471486L01	1	1	1	1	1
2	CONTROL LABEL	GENERAL, OCEANIA, UK, CONT	371286L01	1	1	1	1	1
		CHINA	371287L01	1	1	1	1	1
3	CAUTION LABEL	GENERAL, OCEANIA, UK, CONT	464507-01	1	1	1	1	1
		CHINA	471347L01	1	1	1	1	1
4	MAINTENANCE LABEL	GENERAL, OCEANIA, UK, CONT	255400L01	1	1	1	1	1
		CHINA	255401L01	1	1	1	1	1
5	CAUTION LABEL - SERVICE	GENERAL, OCEANIA, UK, CONT	471180L01	1	1	1	1	1
		CHINA	471348L01	1	1	1	1	1
6	LABEL - TERMINAL		452379-01	1	1	1	1	1
7	LABEL - TERMINAL		452379-02	1	1	1	1	1
8	INSTRUCTION SHEET	GENERAL, OCEANIA, UK, CONT	471384L01	1	1	1	1	1
		CHINA	471386L01	1	1	1	1	1
9	LABEL / R - 404A		453230-01	1	1	1	1	1
10	LABEL - AIR FILTER	GENERAL, OCEANIA, UK, CONT	426177-01		1	1	1	1
		CHINA	455367-01		1	1	1	1
11	CAUTION LABEL		473789L01			1	1	1

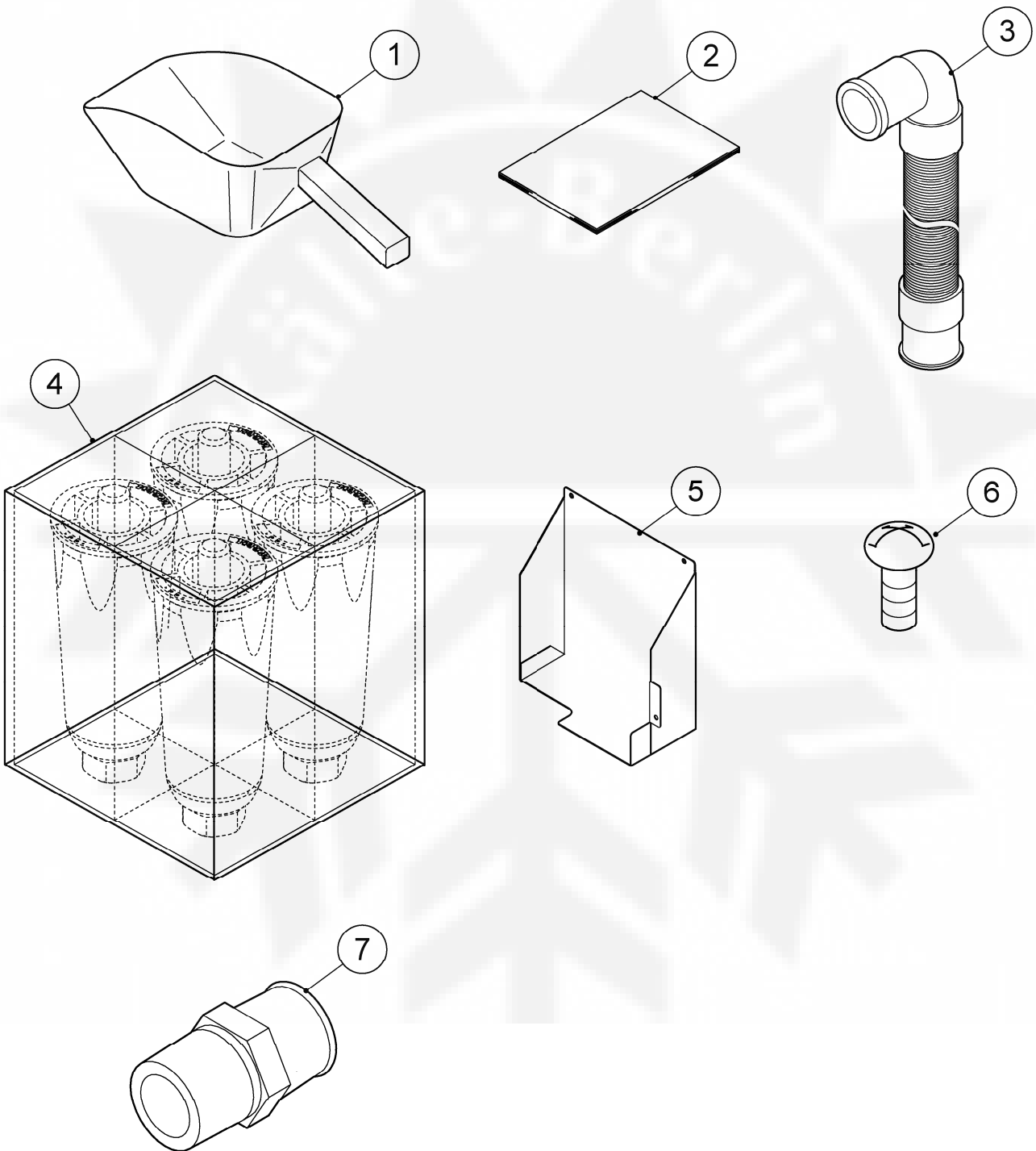

GENERAL, CHINA, OCEANIA, UK, CONT

MODEL: KM-125A									
TITLE: H. ACCESSORIES									
INDEX NO.	DESCRIPTION	MATERIAL OR MODEL NUMBER	PART NUMBER	REQ'D NUMBER					
				T-1	T-2 U-0	U-1 V-0	V-1 V-2	V-3	
1	SCOOP		2H0361-01	1	1	-	-	-	
			1H4123P02			1	1	1	
2	INSTRUCTION MANUAL	GENERAL, OCEANIA, UK, CONT	L1F003101	1	1	1	1	1	
		CHINA	L1F003301	1	1	1	1	1	
3	OUTLET HOSE		P00055-01	1	1	1	1	1	
4	LEG SET - UNC		472736A01	1	1	1	1	1	
5	DUCT - 30		371298M01	1	1	1	1	1	
6	TRUSS HEAD SCREW	4x8	FST0408F0	3	3	3	3	3	
7	DRAIN ADAPTER		472649P01	1	1	1	1	1	