

SêlçÉÖ^l|ã
Q @K@ãã Á^l*
QÉ Á^ãã^lÁF
FGGEJÁÖ^l|ã
Q) KEI JÁEDHEÁI ÁFEÁ ÉCG
QKEI JÁEDHEÁI ÁFEÁ ÉCF
^Tããã f O \æ|çÉã^l|ã Éã^
Qç^l) ^dçq KQ , , Éæ|çÉã^l|ã Éç{

Öã^l dã \ÁP | • @ããã ~ ** ^dÖã à^l^ã^lÁÖT l l ÉOSÖÉPÁ ~ ÁsêlçÉÖ^l|ã

No.	F054-3360
ISSUED:	AUG. 6, 2010
REVISED:	NOV. 9, 2012



HOSHIZAKI FLAKE ICE MAKER

**MODEL FM-750AKE(-N)
FM-1000AKE(-N)**

(F054, F054-C106,
F055, F055-C106)

PARTS LIST
(HE)

K-1 AUG. 2010
A-3 AUG. 2011
B-0 JAN. 2012
B-1 APR. 2013

AUXILIARY CODE

U - 1

The auxiliary code is the first two characters in the serial number. The first character indicates the production year. Years progress or regress in alphabetical order. The series of letters and skipped letters depend on UL listing, production, and model. See the auxiliary code(s) and corresponding year(s) on the front cover.

The second character indicates significant part changes within the same year. Base is "1" and this number advances for each change. If there is no significant part change at the turn of the year, this number starts from "0."

MARKS LOCATED UNDER THE AUXILIARY CODE

- = Part deleted.
- x = Part deleted and replaced by "o" part.
- o = New part in place of "x" part.

FASTENER PART NUMBER

SCREWS

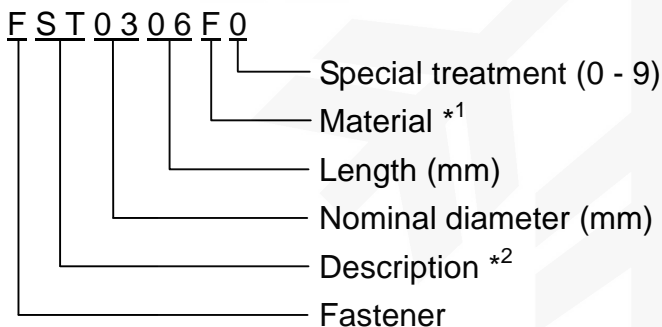

*¹ Material

- F: Steel
- S: Austenitic stainless steel
- M: Martensitic stainless steel
- B: Copper alloy
- P: Polycarbonate
- N: Polyamide
- V: PVC
- A: ABS
- X: Polyacetal
- L: Aluminum

NUTS & WASHERS

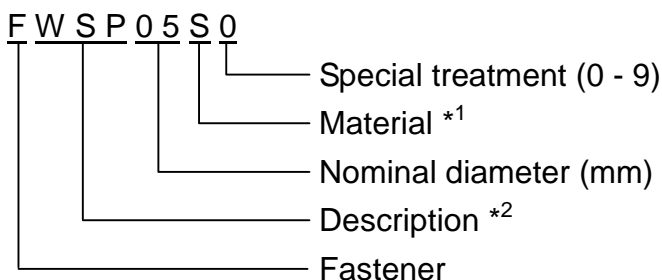

*² Description

- First letter
- S: Machine screw
- T: Tapping screw
- M: Wood screw
- B: Bolt
- W: Washer
- N: Nut

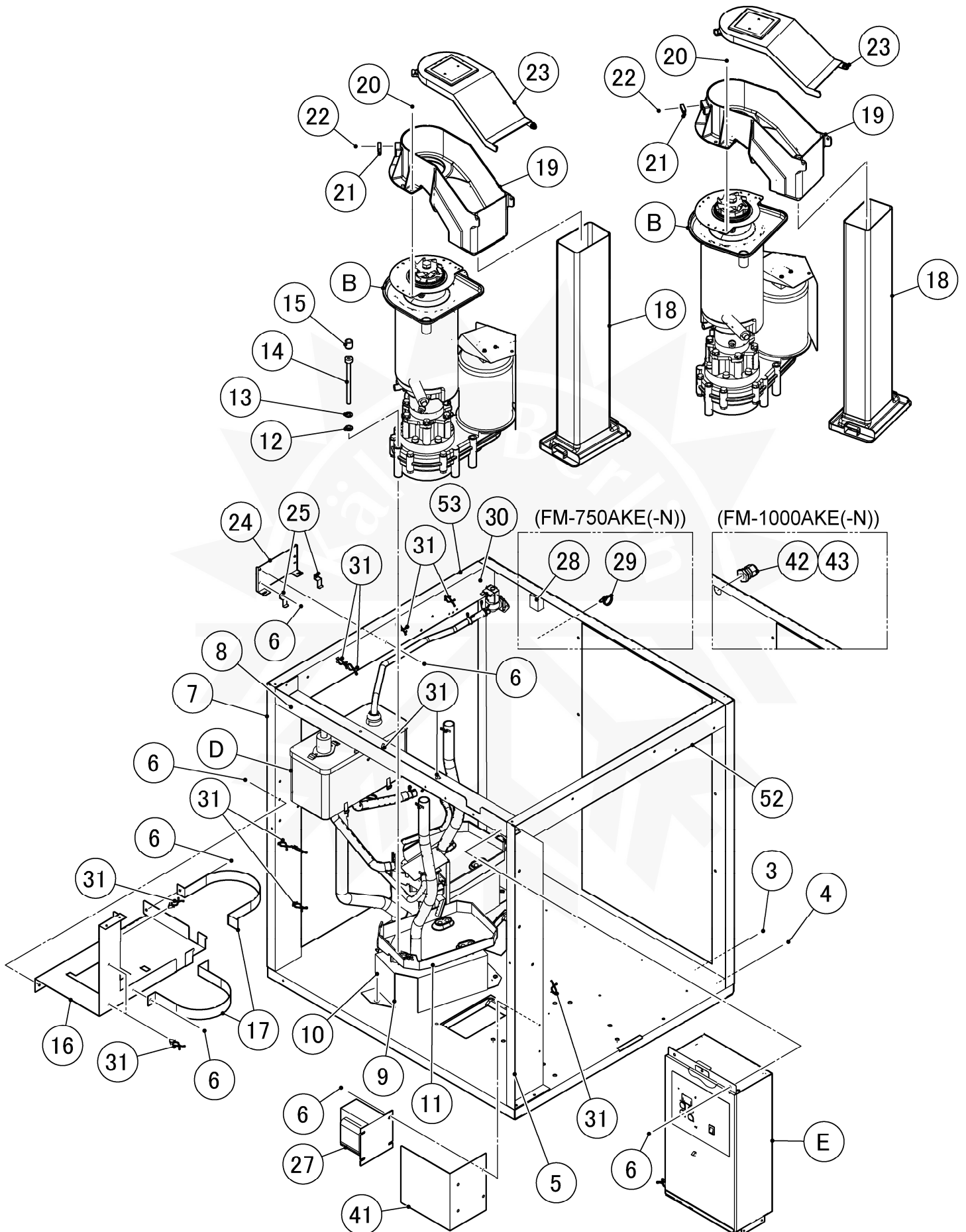

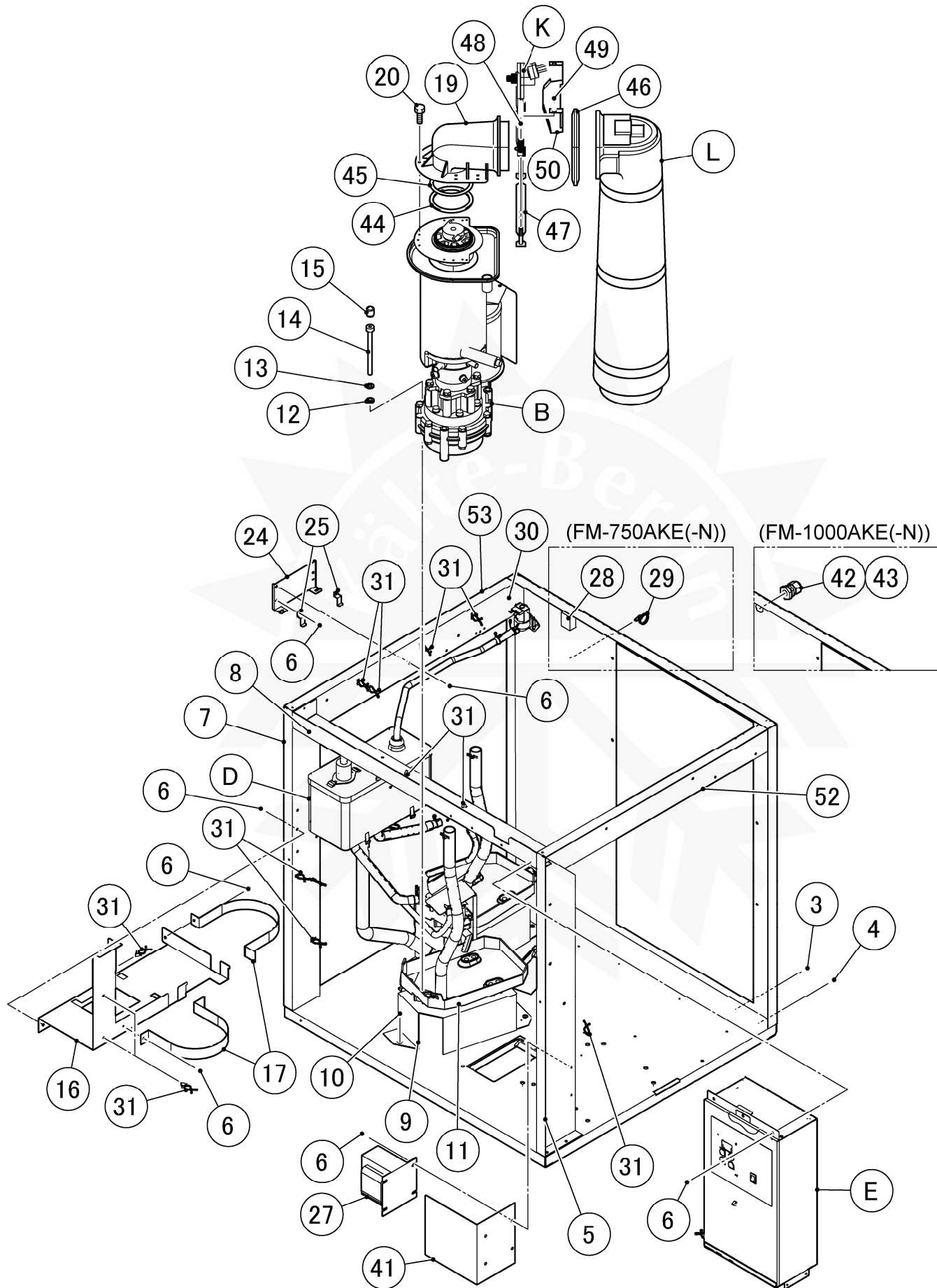

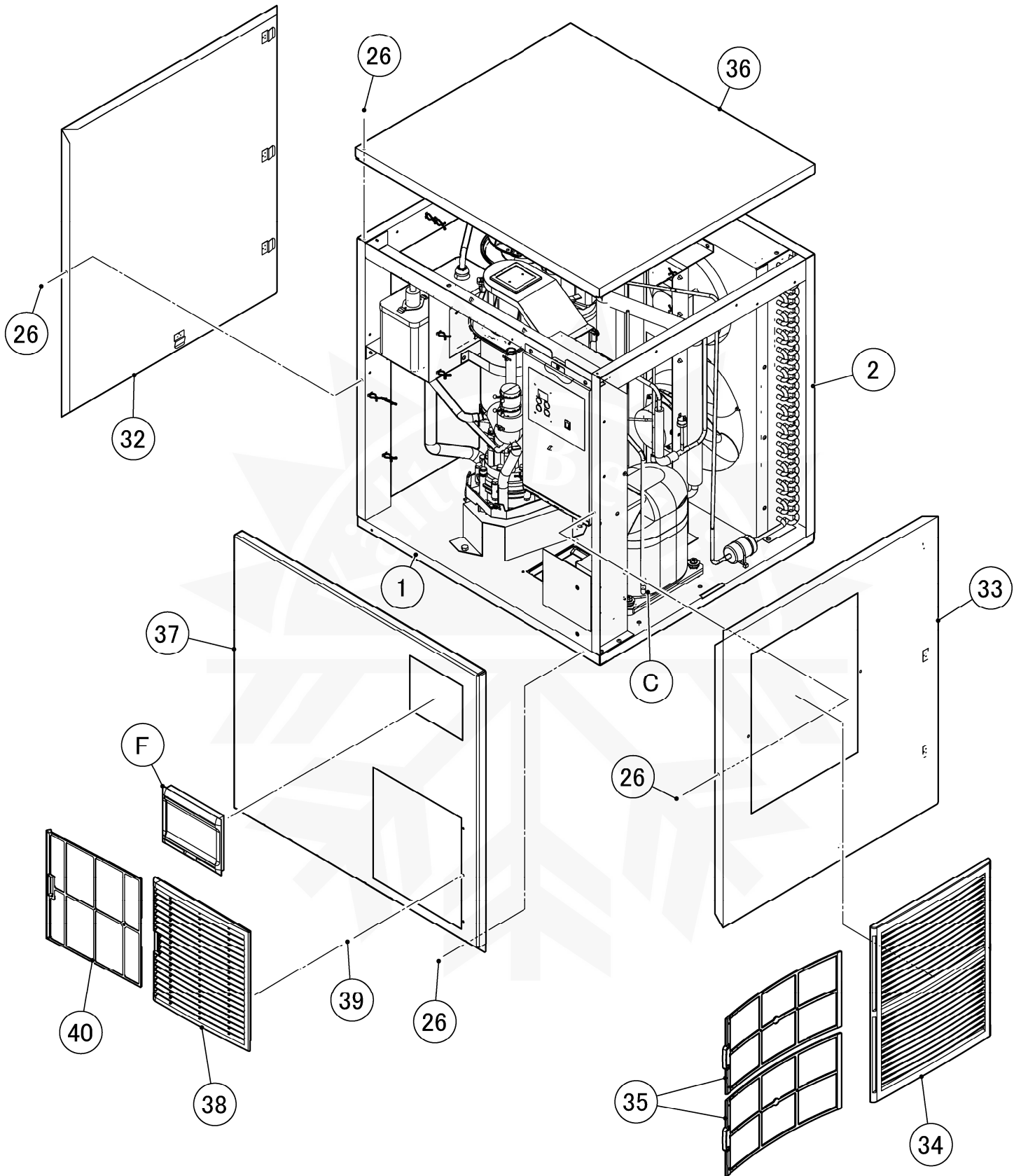

FM-750AKE(-N)
FM-1000AKE(-N)

A. ICE FLAKER ASSY(2/2)

(A-3) and later

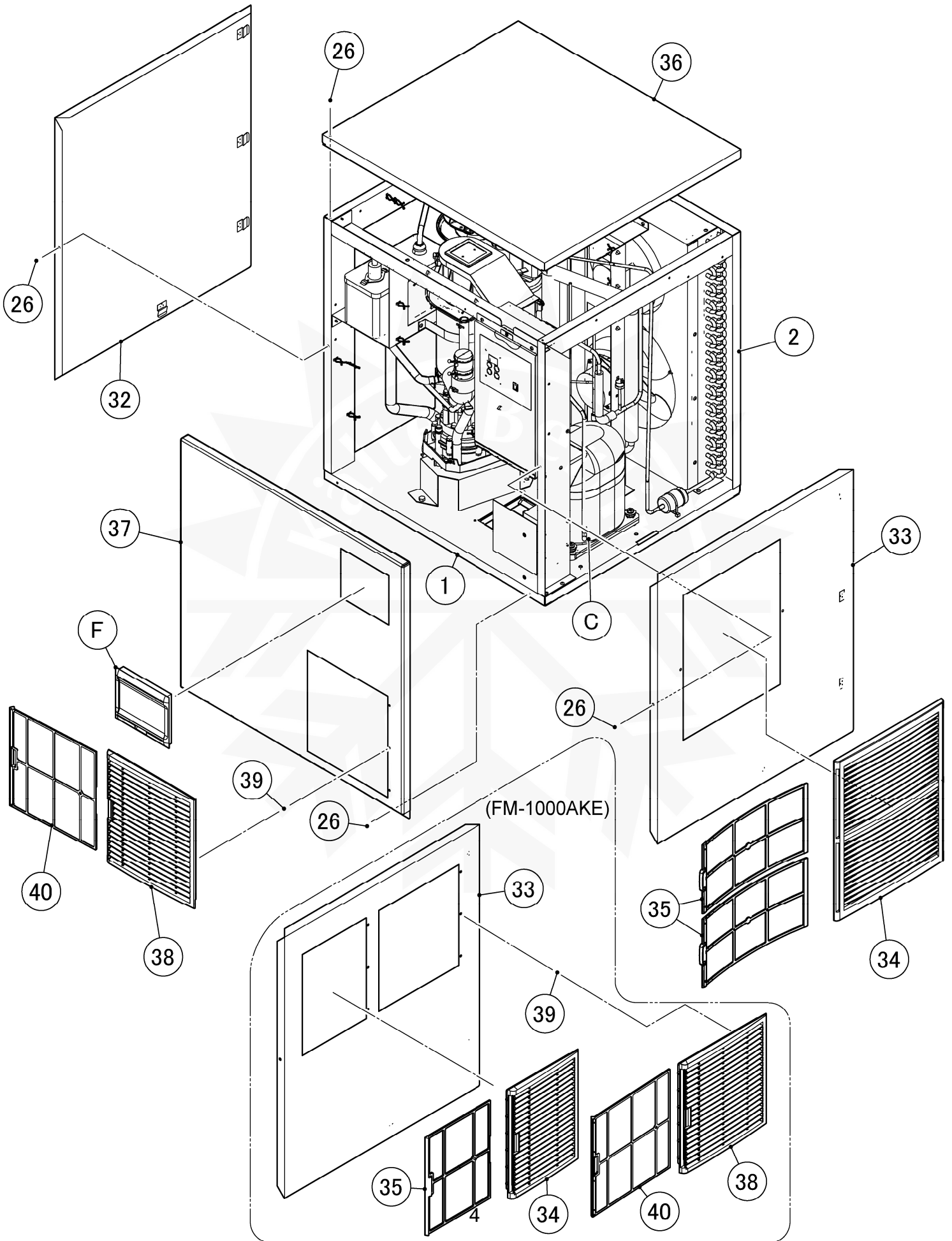

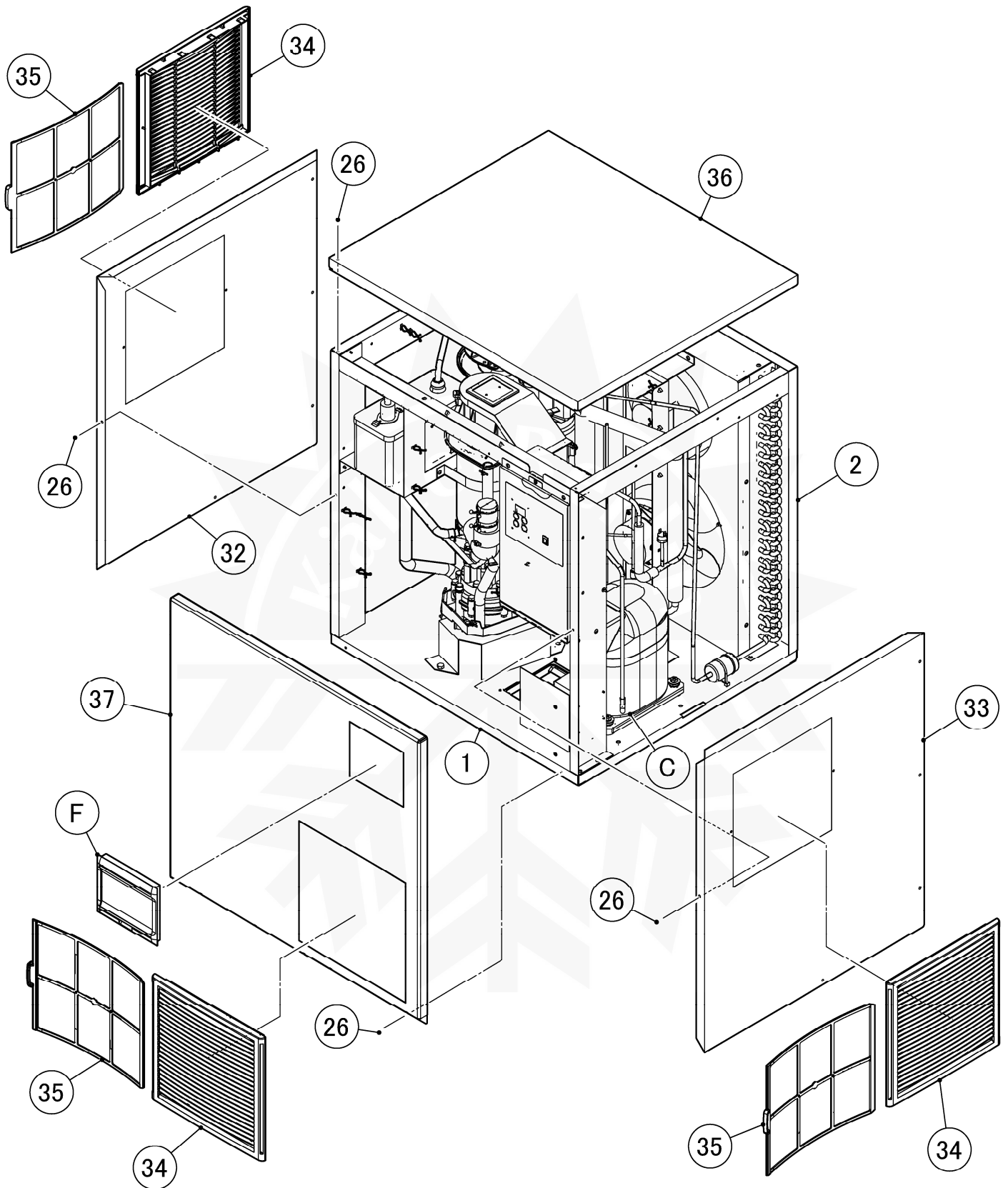

HE

MODEL: FM-750AKE(-N) FM-1000AKE(-N)		TITLE: A. ICE FLAKER ASSY					
INDEX NO.	DESCRIPTION	MATERIAL OR MODEL NUMBER	PART NUMBER	REQ'D NUMBER			
				K-1 A-2	A-3 B-0	B-1	
B	ICE MAKING UNIT	(F054, F055)	259147A02	2	-	-	
			259147003		2	-	
		(F054)	262649A01			2	
		(F055)	262649A02			2	
		(F054-C106, F055-C106)	259147A03	2	-	-	
			259147004		2	-	
	262649A03			2			
C	REFRIGERATION CIRCUIT	(F054, F054-C106)	120943A01	1	-	-	
			120943001		1	-	
			121886A01			1	
		(F055, F055-C106)	120942A01	1	-	-	
			120942001		1	1	
D	WATER CIRCUIT		120946A01	1	-	-	
			120946001		1	1	
E	CONTROL BOX ASSY	(F054, F054-C106)	259156A02	1	1	-	
			263184A02			1	
		(F055, F055-C106)	259156A01	1	1	-	
			263282A01			1	
F	WINDOW PANEL ASSY		348243A03	1	1	1	
G	LABEL LOCATION	(F054, F054-C106)	259135A01	1	-	-	
		(F055, F055-C106)	259135A03	1	-	-	
		(F054)	259135001		1	-	
			259135006			1	
		(F054-C106)	259135002		1	-	
			259135007			1	
		(F055)	259135003		1	-	
			259135008			1	
		(F055-C106)	259135004		1	-	
259135009				1			
J	ACCESSORIES	(F054, F054-C106)	A02525-01	1	1	1	
		(F055, F055-C106)	A02215-01	1	1	1	

HE

MODEL: FM-750AKE(-N) FM-1000AKE(-N)								TITLE: A. ICE FLAKER ASSY							
INDEX NO.	DESCRIPTION	MATERIAL OR MODEL NUMBER	PART NUMBER	REQ'D NUMBER											
				K-1 A-2	A-3 B-0	B-1									
K	BAND ASSY	S-9165	348911A01		2	2									
L	CHUTE ASSY		113006A01		2	2									
1	CHASSIS		259143G01	1	-	-									
			261345G01		1	1									
2	REAR PANEL	(F054, F054-C106)	120940M02	1	1	1									
		(F055, F055-C106)	120940M01	1	1	1									
3	HEX HEAD BOLT (SPRING WASHER AND FLAT WASHER)	(F054, F054-C106 F055)	FBK0512S0	2	2	2									
		(F055-C106)		2	4	4									
4	TRUSS HEAD TAPPING SCREW T2	(F054, F054-C106)	FT20408F0	4	4	4									
		(F055)		4	2	2									
		(F055-C106)		4	-	-									
5	SIDE FRAME (R1)		264212M01	1	1	1									
6	TRUSS HEAD MACHINE SCREW		FST0408F0	30	30	24									
7	SIDE FRAME (L1)		264214M01	1	1	1									
8	FRONT FRAME		259146M01	1	1	-									
			262208M01			1									
9	BRACKET - GEAR MOTOR		374371G01	2	2	2									
10	HEX HEAD BOLT		FBH0812S0	6	6	6									
11	DRAIN PAN		323765G01	2	2	-									
			261640P01			2									
12	SEAL WASHER		458299-01	6	6	6									
13	SPRING WASHER		FWSP08S0	6	6	6									
14	HEXAGON SOCKET HEAD CAP SCREW		461285-01	6	6	6									
15	VINYL CAP		451272-01	6	6	6									
16	BRACKET-RESERVOIR		259148M01	1	-	-									
			261346M01		1	1									
17	BAND		475195M01	2	2	2									
18	BIN CONTROL		375652G03	2	-	-									
19	SPOUT - 70		373329G01	2	-	-									
	SPOUT		104797-01		2	2									

HE

MODEL: FM-750AKE(-N) FM-1000AKE(-N)								TITLE: A. ICE FLAKER ASSY							
INDEX NO.	DESCRIPTION	MATERIAL OR MODEL NUMBER	PART NUMBER	REQ'D NUMBER											
				K-1 A-2	A-3 B-0	B-1									
20	HEX HEAD BOLT (SPRING WASHER AND FLAT WASHER)		FBK0408S0	6	6	6									
21	LEAD SWITCH		431788-01	2	-	-									
22	TRUSS HEAD TAPPING SCREW T2		FT20308M0	2	-	-									
23	SPOUT COVER - 70		256359G01	2	-	-									
24	BRACKET-WATER SUPPLY		475199M01	1	1	-									
			476650M01			1									
25	BRACKET (A) - WATER SUPPLY		474638M01	2	2	-									
26	TRUSS HEAD MACHINE SCREW		FST0408S0	5	5	13									
27	TRANSFORMER		469405-01	1	1	-									
28	CONNECTOR	(F054, F054-C106)	P00246-01	1	1	1									
29	PUSH MOUNT TIE	(F054, F054-C106)	436156-01	1	1	1									
30	PAN HEAD MACHINE SCREW (SPRING WASHER AND FLAT WASHER)		FSK0408S0	1	1	1									
31	CLAMP	No.249	427902-03	15	15	15									
32	SIDE PANEL(L)		234110G01	1	1	-									
			263237M01			1									
33	SIDE PANEL (R)		263238M01			1									
			(F054, F054-C106)	258142G01	1	1	-								
			(F055, F055-C106)		1	-	-								
				261367G01		1	-								
34	LOUVER		121931P01			3									
			(F054, F054-C106)	1A1329-01	1	1	-								
			(F055, F055-C106)		1	-	-								
			1A0548-01		1	-									
35	AIR FILTER		262259G01			3									
			(F054, F054-C106)	2A4128G01	2	2	-								
			(F055, F055-C106)		2	-	-								
			2A2063G01		1	-									
36	TOP PANEL		259153M01	1	1	1									
37	FRONT PANEL (A)		120949M01	1	1	-									
				122242G01			1								

HE

MODEL: FM-750AKE(-N) FM-1000AKE(-N)		TITLE: A. ICE FLAKER ASSY					
INDEX NO.	DESCRIPTION	MATERIAL OR MODEL NUMBER	PART NUMBER	REQ'D NUMBER			
				K-1 A-2	A-3 B-0	B-1	
38	LOUVER A	(F054, F054-C106)	1A0547-01	1	1	-	
		(F055)		1	2	-	
		(F055-C106)		1	1	-	
39	PUSH RETAINER	(F054, F054-C106)	4A2414-01	3	3	-	
		(F055)		3	9	-	
		(F055-C106)		3	3	-	
40	AIR FILTER A	(F054, F054-C106)	2A2062G01	1	1	-	
		(F055)		1	2	-	
		(F055-C106)		1	1	-	
41	COVER - TRANSFORMER		475235M01	1	1	-	
42	PERFECT LOCK	(F055, F055-C106)	466342-01	1	1	1	
43	POWER SUPPLY CORD	(F055, F055-C106)	466418-01	1	1	1	
44	RING		432661-02		2	2	
45	O-RING	4DG70	7616-G070		2	2	
46	PACKING		454256-01		2	2	
47	BAND (B)		459995G01		2	2	
48	FLANGE NUT		FNHF06S0		6	6	
49	NUT		FNH106S0		10	10	
50	DRIP GUIDE		350725-01		2	2	
51	CLAMP		428644-03			2	
52	SIDE FRAME (R2)		264213M01	1	1	1	
53	SIDE FRAME (L2)		264215M01	1	1	1	

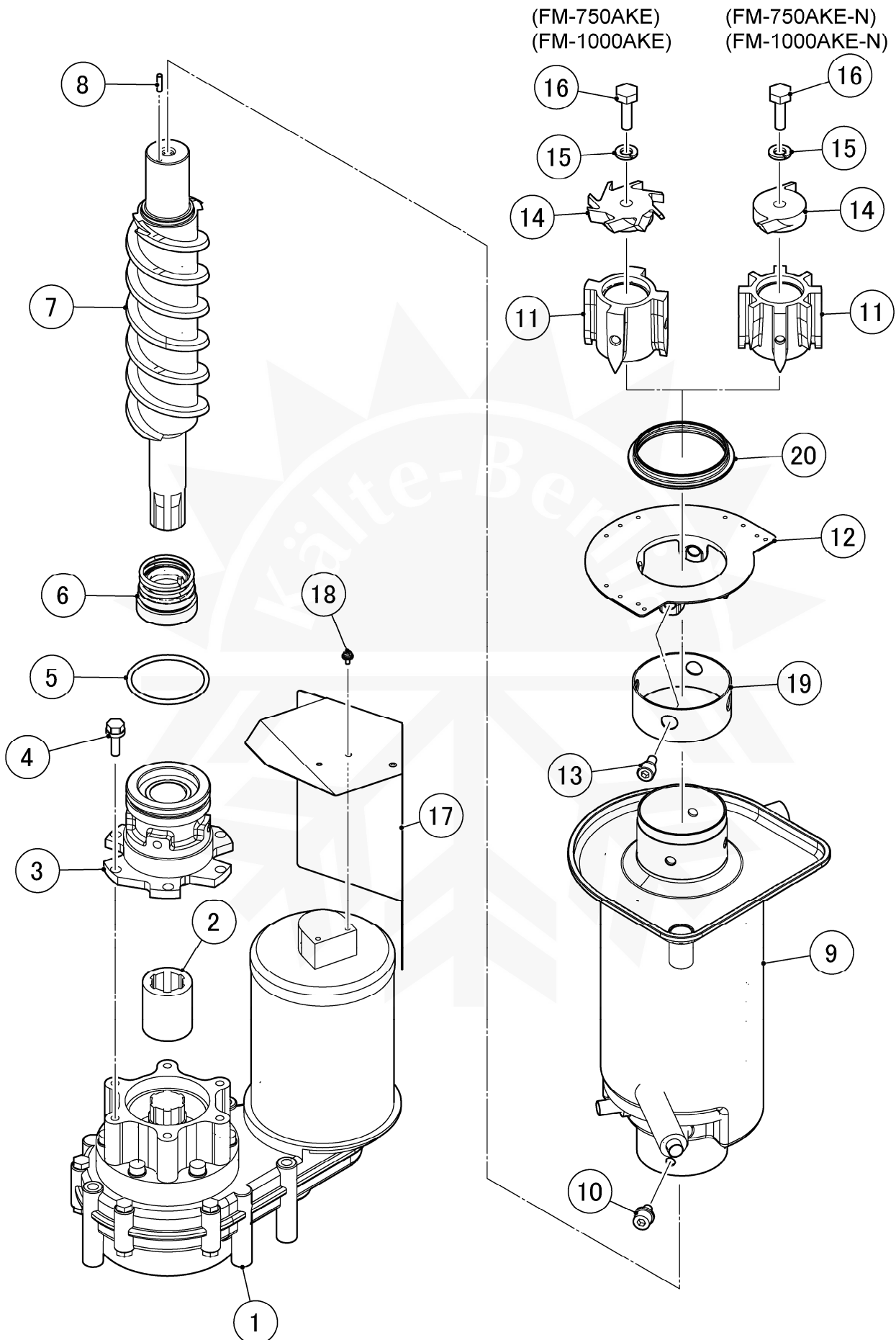

HE

MODEL: FM-750AKE(-N) FM-1000AKE(-N)								TITLE: B. ICE MAKING UNIT							
INDEX NO.	DESCRIPTION	MATERIAL OR MODEL NUMBER	PART NUMBER	REQ'D NUMBER											
				K-1 A-2	A-3 B-0	B-1									
1	GEAR MOTOR		466223-01	1	1	1									
2	COUPLING		414137-01	1	1	1									
3	HOUSING		206657G02	1	1	1									
4	HEX.HEAD BOLT W/WASHER (SW)		461888-01	6	6	6									
5	O-RING		7616-G065	1	1	1									
6	MECHANICAL SEAL		432492-01	1	1	1									
7	AUGER		120863G02	1	1	1									
8	PIN		713S-0416	1	1	1									
9	EVAPORATOR		258997G01	1	1	1									
10	SCREW		P01719-01	4	4	4									
11	EXTRUDING HEAD	(F054, F055)	327097G02	1	1	-									
			327097G04			1									
		(F054-C106, F055-C106)	216531G02	1	1	1									
12	FLANGE - 70		372207M01	1	-	-									
			476246G01		1	1									
13	SEAL BOLT - M8		P01768-01	4	4	4									
14	CUTTER	(F054, F055)	317071-02	1	1	1									
		(F054-C106, F055-C106)	327145-01	1	1	1									
15	SPRING WASHER		FWSP10S0	1	1	1									
16	SCREW-BOLT		458101-01	1	1	1									
17	COVER-GEAR MOTOR		475224G01	1	1	1									
18	PAN HEAD MACHINE SCREW (SPRING WASHER AND FLAT WASHER)		FSK0408S0	2	2	2									
19	BELT HEATER		469322-01	1	1	-									
		(F054-C106, F055,F055-C106)	P02370-01			1									
20	PACKING - SPOUT		473494R01	1	1	-									

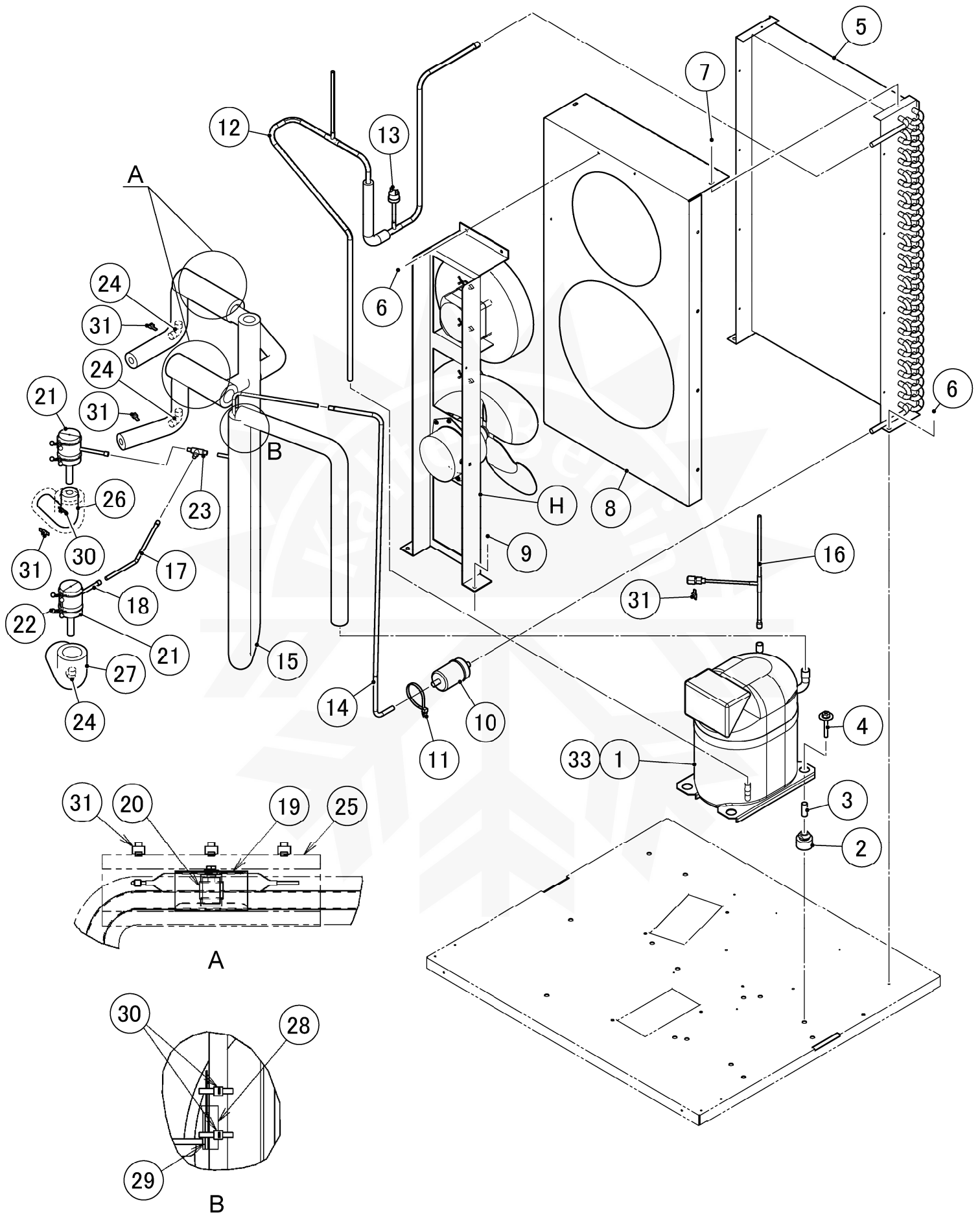

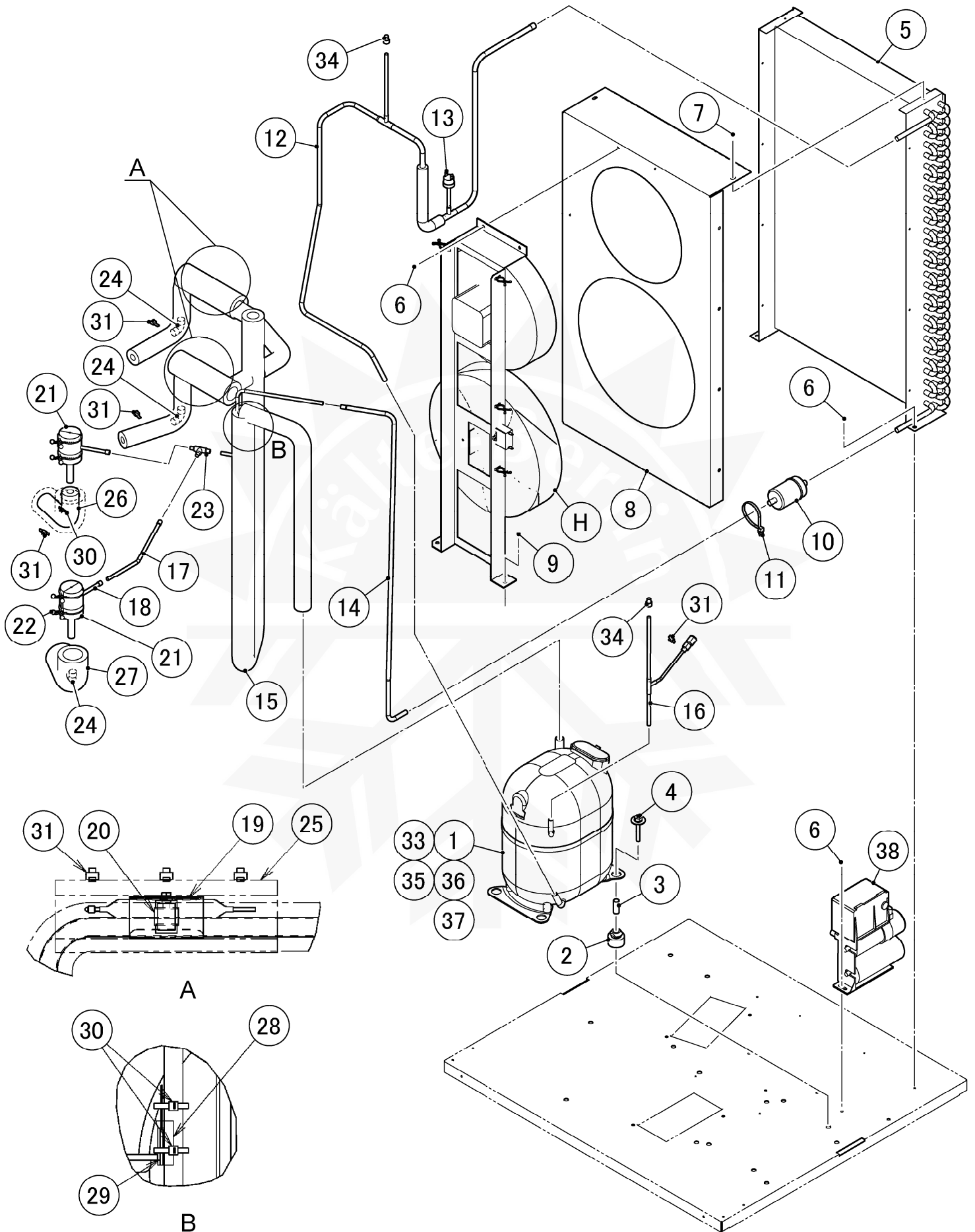

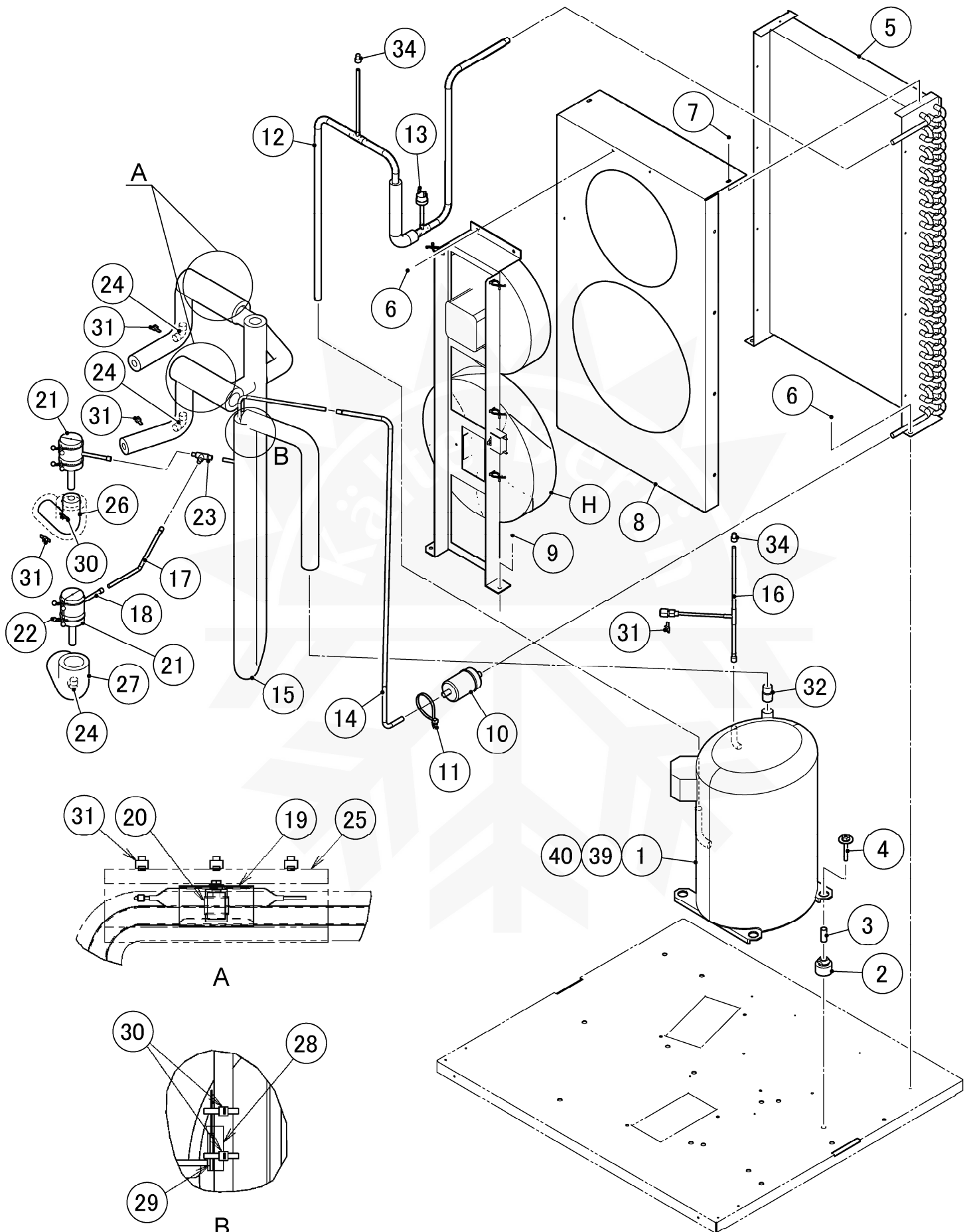

HE

MODEL: FM-750AKE(-N) FM-1000AKE(-N)								TITLE: C. REFRIGERATION CIRCUIT							
INDEX NO.	DESCRIPTION	MATERIAL OR MODEL NUMBER	PART NUMBER	REQ'D NUMBER											
				K-1 A-2	A-3 B-0	B-1									
H	FAN MOTOR ASSY		241617A01	1	1	-									
			262065A01			1									
1	COMPRESSOR	(F054, F054-C106)	4A1581-01	1	1	-									
			P02532-01			1									
		(F055, F055-C106)	466224-01	1	1	-									
			P02588-01			1									
2	GROMMET	(F054, F054-C106)	P00846-01			4									
			434922-02	4	4	-									
		(F055, F055-C106)		4	4	4									
3	SPACER	(F054, F054-C106)	P00847-01			4									
			434921-01	4	4	-									
		(F055, F055-C106)		4	4	4									
4	BOLT	(F054, F054-C106)	436206-04			4									
			436206-01	4	4	-									
		(F055, F055-C106)		4	4	4									
5	CONDENSER-AIR COOLED		P00729-01	1	1	1									
6	TRUSS HEAD MACHINE SCREW	(F054, F054-C106)	FST0408F0	4	4	6									
		(F055, F055-C106)		4	4	4									
7	TRUSS HEAD TAPPING SCREW T2		FT20408F0	16	16	16									
8	SHROUD		114398-01	1	-	-									
			121539M01		1	-									
			121787M01			1									
9	HEX HEAD BOLT (SPRING WASHER AND FLAT WASHER)		FBK0512S0	2	2	2									
10	DRIER		462965-01	1	1	1									
11	TIE		436156-02	1	1	1									
12	COPPER TUBE(A) - H	(F054, F054-C106)	259151G01	1	1	-									
			262187G01			1									
		(F055, F055-C106)	259149G01	1	-	-									
			261342G01		1	1									
13	PRESSURE SWITCH	R134a,R22,R404A COPPER TUBE A/H	459863-06	1	1	1									
14	COPPER TUBE(B) - H		374373M01	1	1	1									

HE

MODEL: FM-750AKE(-N) FM-1000AKE(-N)				TITLE: C. REFRIGERATION CIRCUIT			
INDEX NO.	DESCRIPTION	MATERIAL OR MODEL NUMBER	PART NUMBER	REQ'D NUMBER			
				K-1 A-2	A-3 B-0	B-1	
15	COPPER TUBE(L)	(F054, F054-C106)	120945G01	1	-	-	
			121536G01		1	-	
			121881G01				1
		(F055, F055-C106)	120944G01	1	-	-	
			121534G01		1	1	
16	COPPER TUBE-ACCESS VALVE	(F054, F054-C106)	476690G01			1	
			466222G01	1	1	-	
		(F055, F055-C106)		1	1	1	
17	COPPER TUBE(E)/H		475197M01	1	-	-	
			476240M01		1	1	
18	EXPANSION VALVE		453868-01	2	2	2	
19	HOLDER - EXP. VALVE 1/2		3A0112-01	2	2	2	
20	CLAMP		443461-01	2	2	2	
21	VALVE COVER		3Y3196P01	2	2	2	
22	CLAMP		P00752-01	4	4	4	
23	TEE		4R3125-01	1	1	1	
24	ELBOW		417395-03	4	4	4	
25	INSULATION TUBE		H72949B15	2	2	2	
26	INSULATION TUBE		H71333B35	2	2	2	
27	INSULATION TUBE		H73858B28	2	2	2	
28	HOLDER - THERMISTOR	(F054, F054-C106)	427430-01	1	1	1	
		(F055, F055-C106)	438247-01	1	1	1	
29	THERMISTOR ASSY		475407G01	1	1	1	
30	TIE	CV-150	7920-0003	6	6	6	
31	TIE	(F054, F054-C106)	7920-0010	14	14	15	
		(F055, F055-C106)		14	14	14	
32	REDUCER	(F055, F055-C106)	420915-12	1	1	-	
33	PROTECTOR	(F054, F054-C106)	4A1877-04	1	1	-	
			P02534-01			1	
34	LOCKRING STOPPER		P01677-01			1	
35	CARTON PACKING	(F054, F054-C106)	P02535-01			1	
36	METRIC SCREW	(F054, F054-C106)	P02657-01			1	
37	TERMINAL COVER	(F054, F054-C106)	P02536-01			1	
38	BOX WITH ELECTRICAL COMPONE	(F054, F054-C106)	P02533-01			1	

HE

MODEL: FM-750AKE(-N) FM-1000AKE(-N)		TITLE: C. REFRIGERATION CIRCUIT					
INDEX NO.	DESCRIPTION	MATERIAL OR MODEL NUMBER	PART NUMBER	REQ'D NUMBER			
				K-1 A-2	A-3 B-0	B-1	
39	CRANKCASE HEATER	(F055, F055-C106)	4A5397-01			1	
40	TERMINAL COVER	(F055, F055-C106)	P02823-01			1	



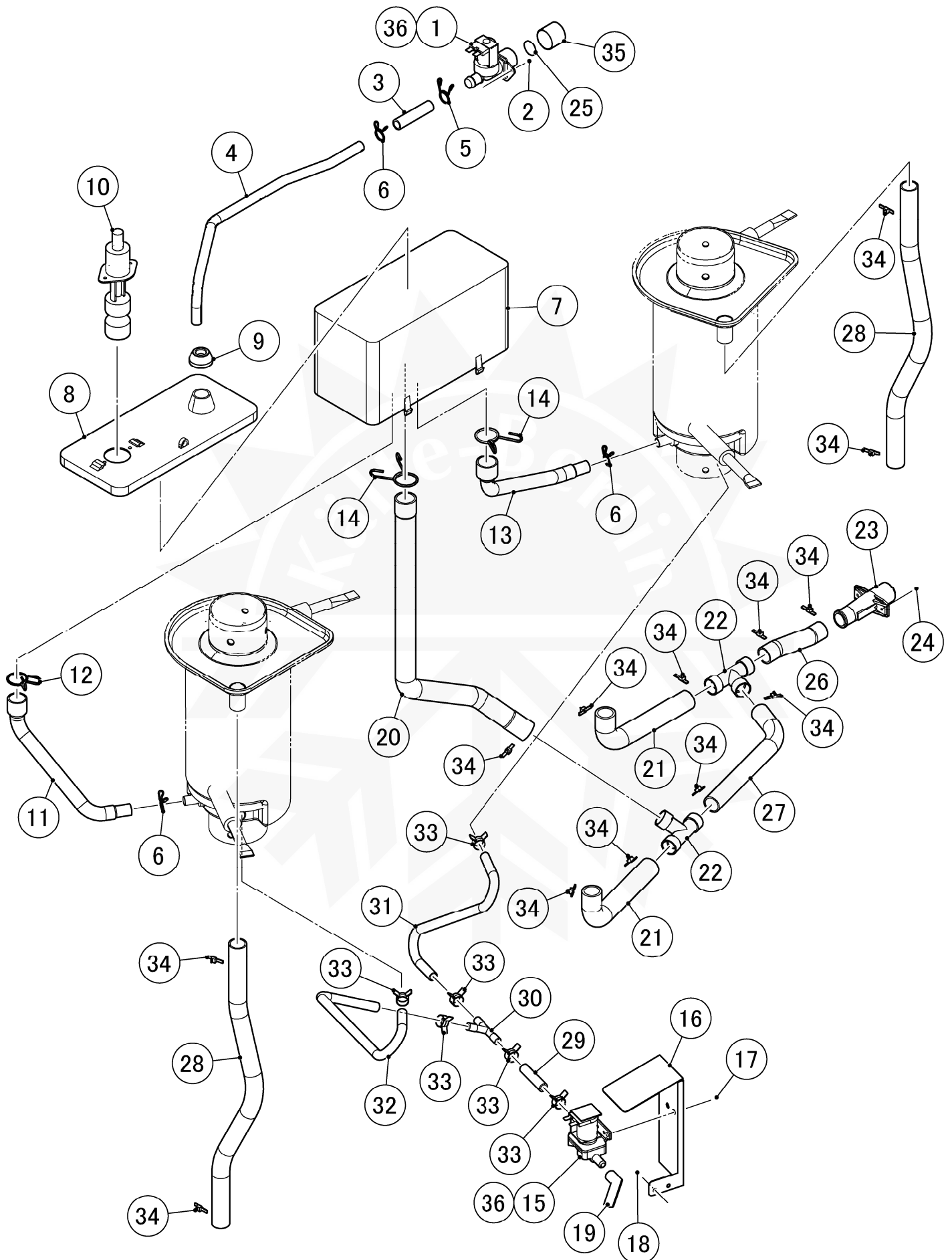

HE

MODEL: FM-750AKE(-N) FM-1000AKE(-N)								TITLE: D. WATER CIRCUIT			
INDEX NO.	DESCRIPTION	MATERIAL OR MODEL NUMBER	PART NUMBER	REQ'D NUMBER							
				K-1 A-2	A-3 B-0	B-1					
1	WATER VALVE		452993-01	1	1	1					
2	HEX HEAD BOLT		FBH0408S0	2	2	2					
3	SILICONE HOSE		H11014060	1	1	1					
4	PIPE-WATER SUPPLY		374379M01	1	-	-					
			375950M01		1	1					
5	HOSE CLAMP		435934-03	1	1	1					
6	HOSE CLAMP		435934-02	3	3	3					
7	RESERVOIR(B)		114487-01	1	1	1					
8	RESERVOIR COVER		112582-01	1	1	1					
9	COVER - RESERVOIR INLET		415094-01	1	1	1					
10	FLOAT SWITCH		458279-01	1	1	1					
11	HOSE (A)		374346R01	1	1	1					
12	HOSE CLAMP		427443-10	1	1	1					
13	HOSE (B)		374347R01	1	1	1					
14	HOSE CLAMP		427443-08	2	2	2					
15	WATER VALVE		468655-01	1	1	1					
16	VALVE BRACKET		461831-01	1	1	1					
17	HEX HEAD BOLT (SPRING WASHER AND FLAT WASHER)		FBK0508F0	2	2	2					
18	PAN HEAD MACHINE SCREW (SPRING WASHER AND FLAT WASHER)		FSK0408F0	2	2	2					
19	DRAIN PIPE		460263-01	1	1	1					
20	HOSE(B)		360004-01	1	1	1					
21	HOSE(C)		475198G01	2	2	2					
22	TEE		364488-01	2	2	2					
23	DRAIN PIPE		321035-01	1	1	1					
24	TRUSS HEAD TAPPING SCREW T2		FT20410S0	2	2	2					
25	FILTER		464377G01	1	1	1					
26	PVC HOSE (FOOD GRADE)		HD1923120	1	-	-					
			HD1923080		1	1					
27	PVC HOSE (FOOD GRADE)		HD1923250	1	-	-					
			HD1923270		1	1					
28	PVC HOSE (FOOD GRADE)		HD1923460	2	2	2					
29	PVC HOSE (FOOD GRADE)		HD0912050	1	1	1					

HE

MODEL: FM-750AKE(-N) FM-1000AKE(-N)				TITLE: D. WATER CIRCUIT			
INDEX NO.	DESCRIPTION	MATERIAL OR MODEL NUMBER	PART NUMBER	REQ'D NUMBER			
				K-1 A-2	A-3 B-0	B-1	
30	JOINT		450297-04	1	1	1	
31	PVC HOSE (FOOD GRADE)		HD0912400	1	1	1	
32	PVC HOSE (FOOD GRADE)		HD0912500	1	1	1	
33	CLAMP		423866-03	6	6	6	
34	TIE	CV-150	7920-0003	13	13	13	
35	CAP		417323-01	1	1	1	
36	NOISE KILLER		450363-01		2	2	

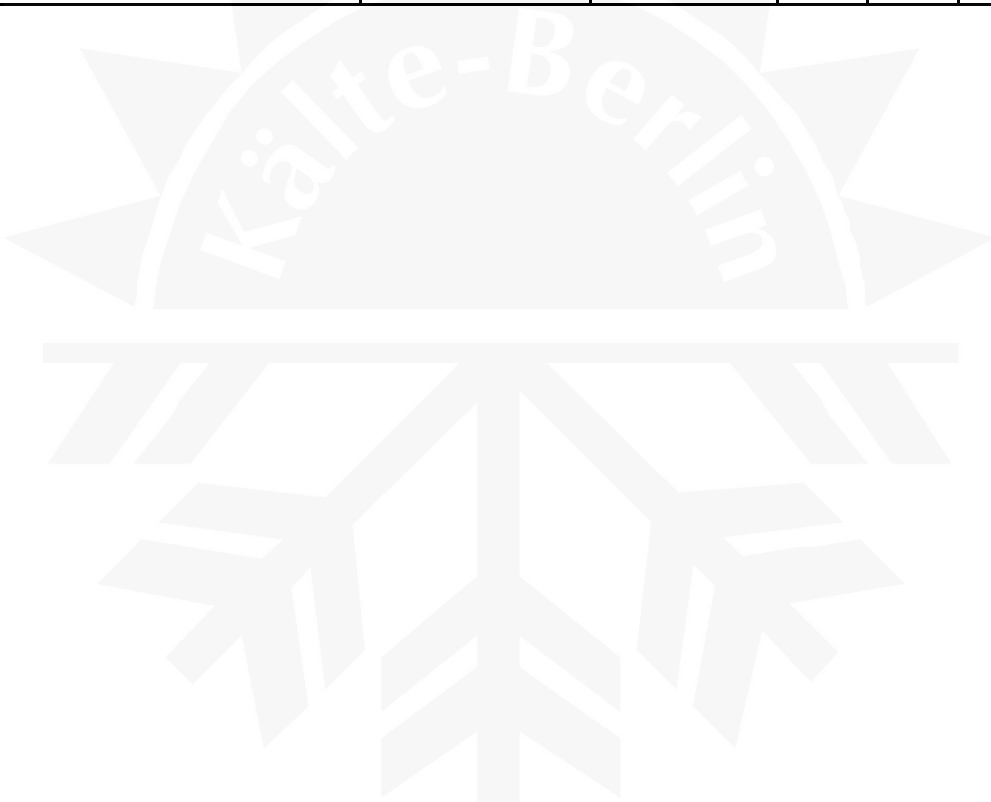

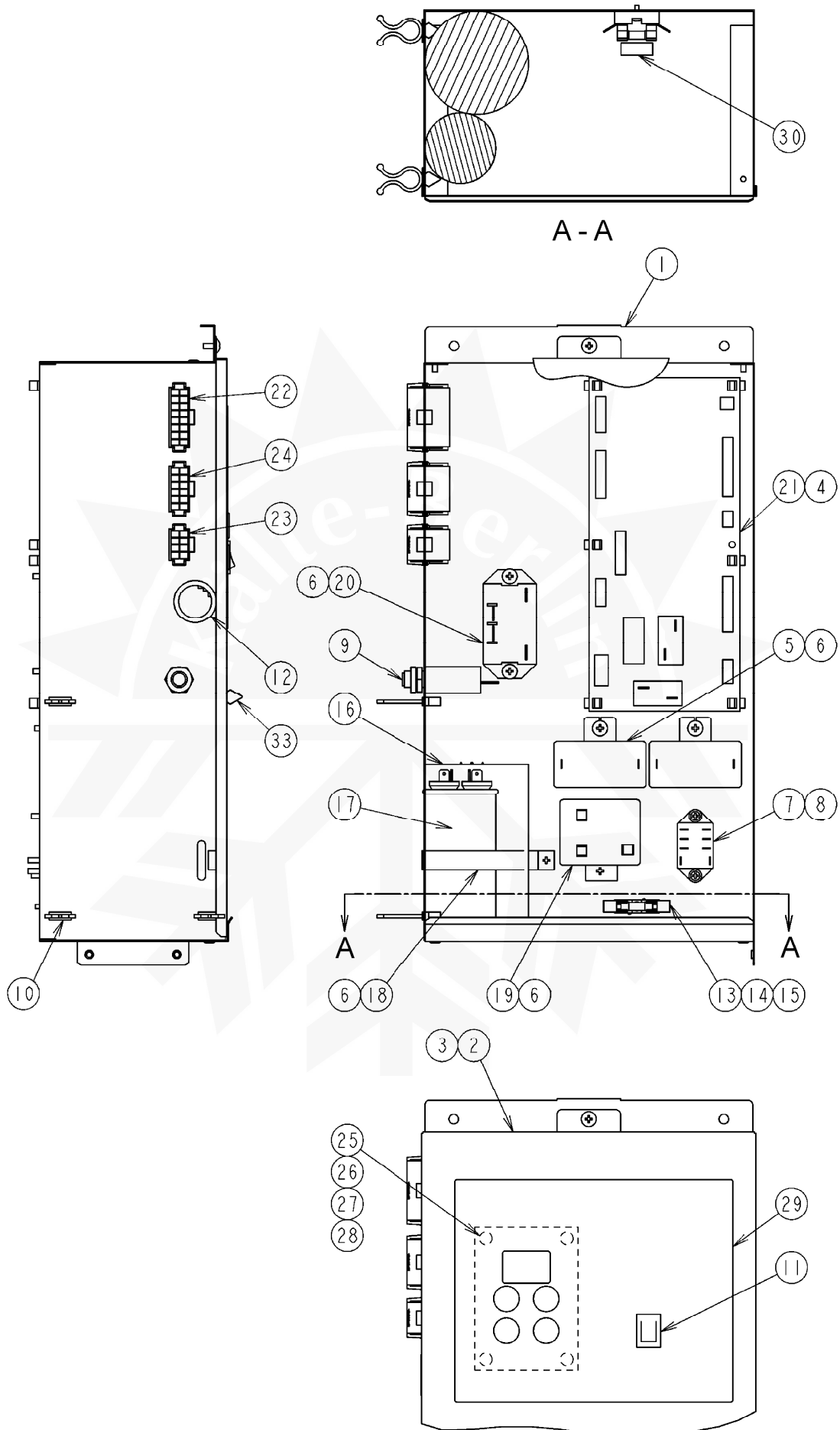

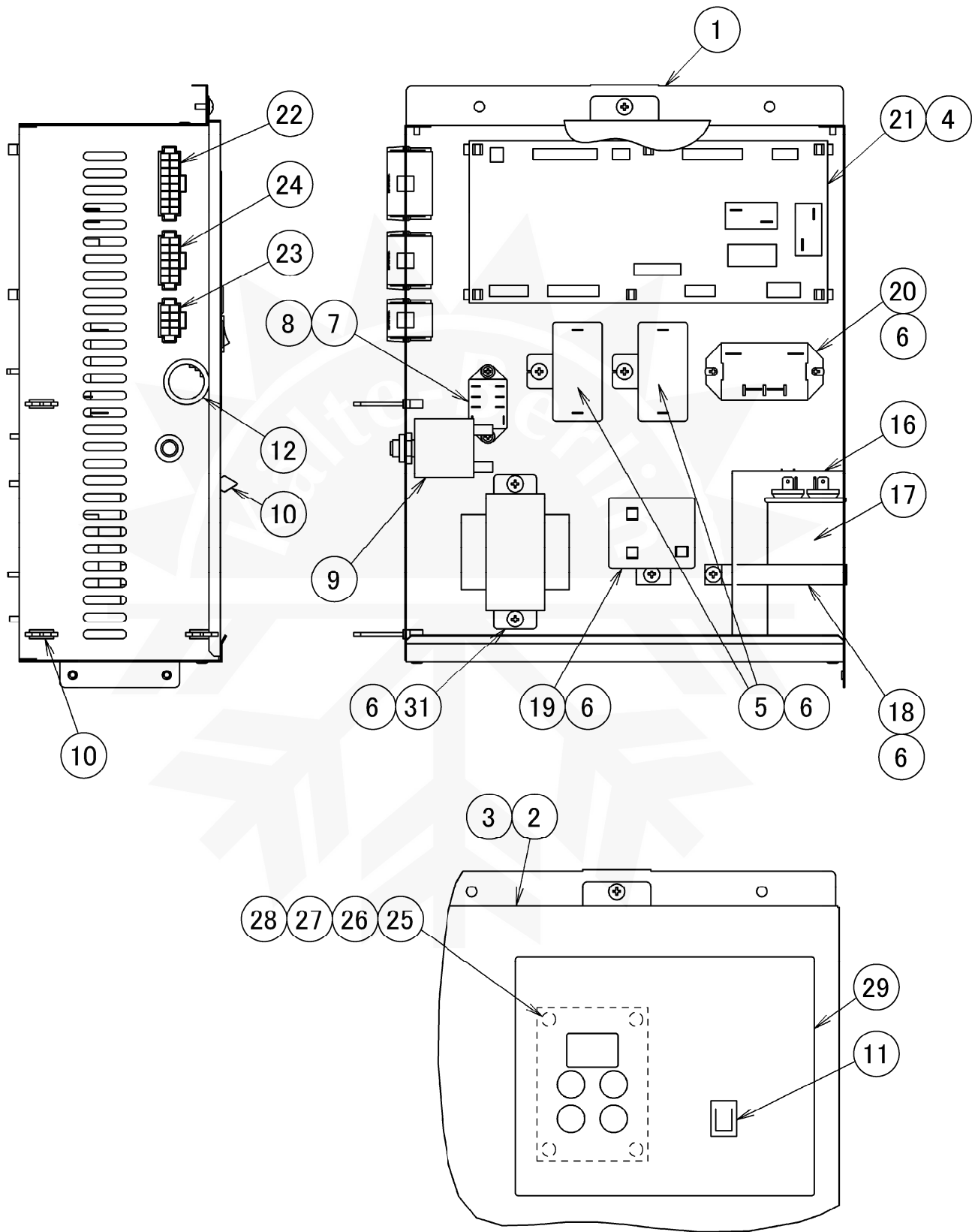

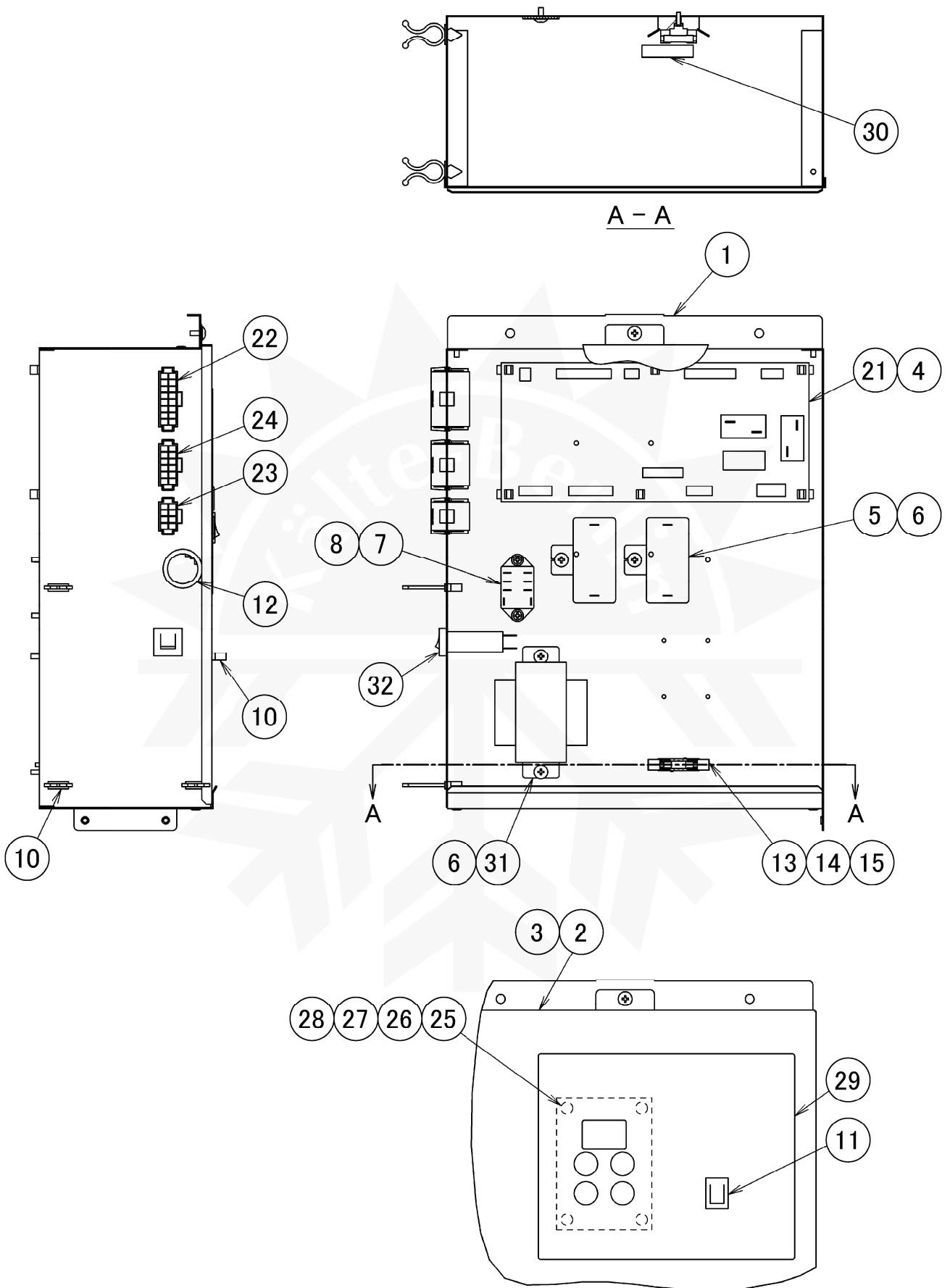

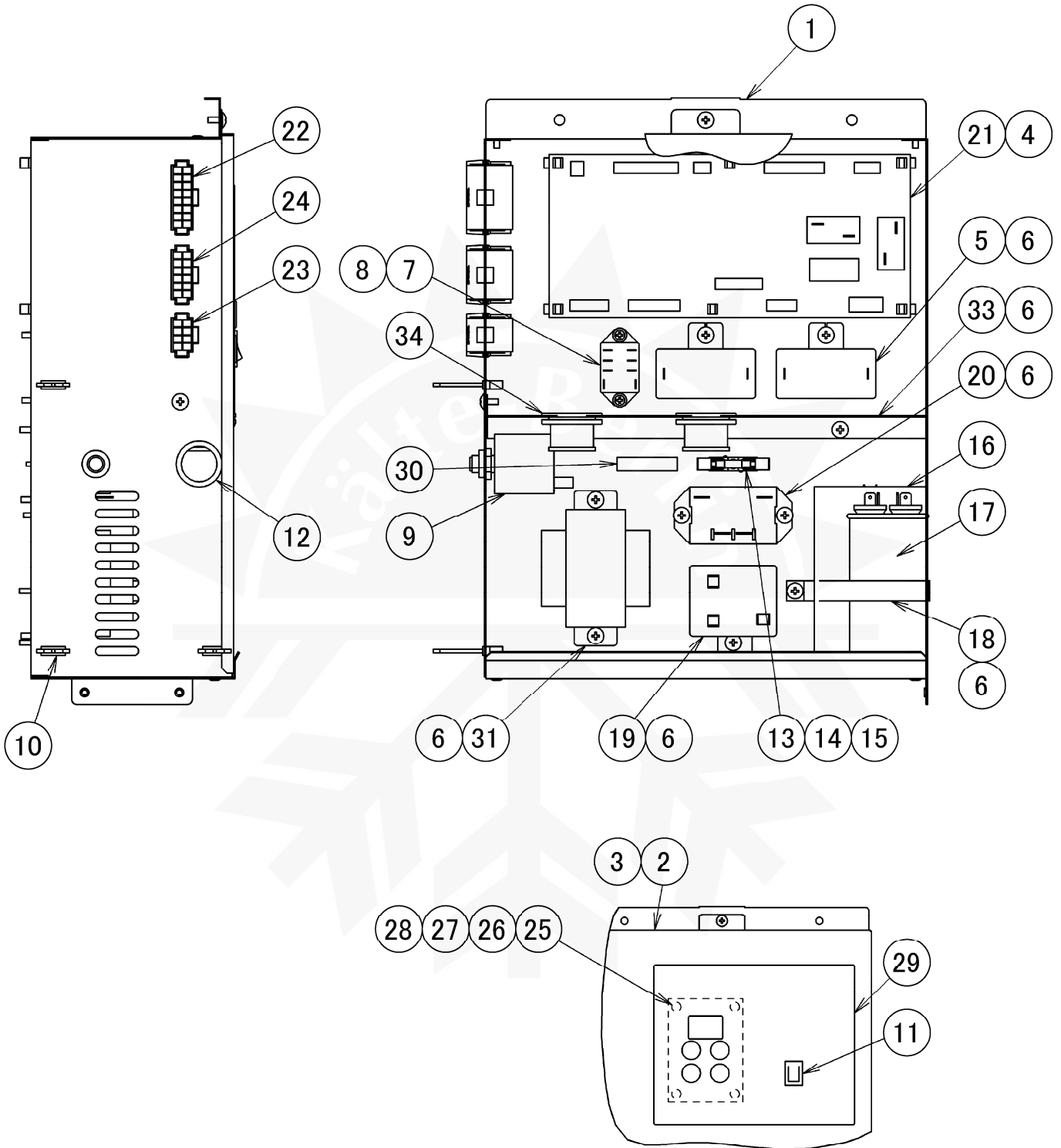

HE

MODEL: FM-750AKE(-N) FM-1000AKE(-N)								TITLE: E. CONTROL BOX ASSY							
INDEX NO.	DESCRIPTION	MATERIAL OR MODEL NUMBER	PART NUMBER	REQ'D NUMBER											
				K-1 A-2	A-3 B-0	B-1									
1	CONTROL BOX		120948G01	1	1	-									
		(F054, F054-C106)	121824G01			1									
		(F055, F055-C106)	122174G01			1									
2	COVER - CONTROL BOX		374380G01	1	1	-									
			376330G01			1									
3	TRUSS HEAD MACHINE SCREW		FST0408F0	1	1	1									
4	BOARD SUPPORT		414929-01	6	6	6									
5	CAPACITOR		459704-01	2	2	2									
6	TRUSS HEAD TAPPING SCREW T2	(F054, F054-C106)	FT20408F0	4	4	4									
		(F055, F055-C106)	FT20408F0	6	6	10									
7	RELAY		406132-08	1	1	1									
8	TAPPING SCREW		431415-01	2	2	2									
9	CIRCUIT PROTECTOR	(F054, F054-C106)	425201-05	1	1	-									
		(F055, F055-C106)	425201-03	1	1	1									
10	CLAMP	No.249	427902-03	4	4	3									
11	ROCKER SWITCH		460681-01	1	1	1									
12	BUSHING		428394-05	1	1	1									
13	FUSE HOLDER		4Y2547-01	1	1	1									
14	FUSE		451924-02	1	1	1									
15	PAN HEAD TAPPING SCREW T2		FT50308F0	1	1	1									
16	START CAPACITOR	(F054, F054-C106)	3A0076-14	1	1	-									
		(F055, F055-C106)	3A0076-18	1	1	1									
17	CAPACITOR	(F054, F054-C106)	4A1631-01	1	1	-									
		(F055, F055-C106)	3A2005-13	1	1	1									
18	STRAP	(F054, F054-C106)	434174-04	1	1	-									
		(F055, F055-C106)	434174-02	1	1	1									
19	STARTER	(F054, F054-C106)	4A1107-02	1	1	-									
		(F055, F055-C106)	4A1107-13	1	1	1									
20	POWER RELAY	(F055, F055-C106)	449000-01	1	1	-									
			P00034-01			1									
21	CONTROLLER BOARD -09CM		P01372-99	1	1	1									
22	HARNESS (A)		374365G01	1	1	-									
			376352G01			1									

HE

MODEL: FM-750AKE(-N) FM-1000AKE(-N)				TITLE: E. CONTROL BOX ASSY			
INDEX NO.	DESCRIPTION	MATERIAL OR MODEL NUMBER	PART NUMBER	REQ'D NUMBER			
				K-1 A-2	A-3 B-0	B-1	
23	HARNESS (B)		473845G01	1	1	1	
24	HARNESS (C)		374366G01	1	1	1	
25	SPACER		451658-05	4	4	4	
26	OPERATION BOARD -09CM		P01373-01	1	1	1	
27	FLAT WASHER		FWPL03P0	4	4	4	
28	NUT		FNH103F0	4	4	4	
29	CONTROL LABEL		374148L01	1	1	1	
30	LABEL - FUSE		455750-02	1	1	-	
			477494L01			1	
31	TRANSFORMER		P02623-01			1	
32	PROTECTOR	(F054, F054-C106)	440972-07			1	
33	SEPARATOR/BOX	(F055, F055-C106)	377045M01			1	
34	GROMMET	(F055, F055-C106)	4H2568-01			2	

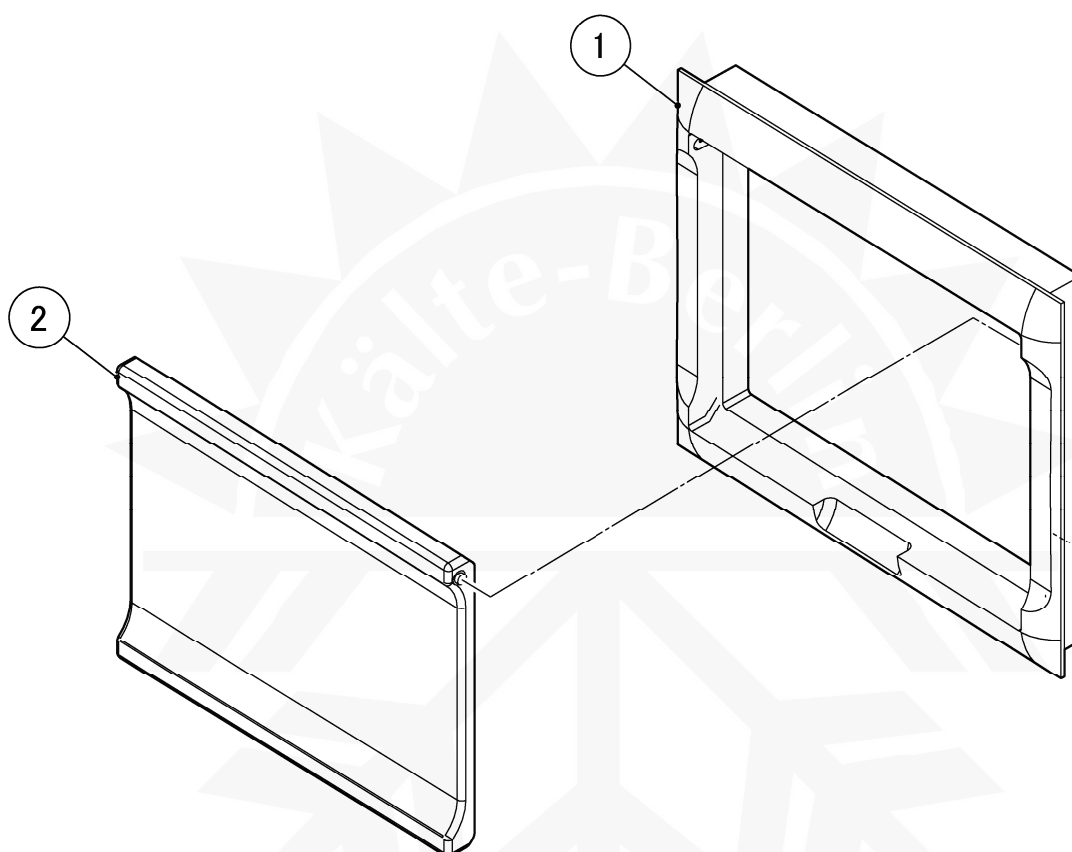

MODEL: FM-750AKE(-N) FM-1000AKE(-N)								TITLE: F. WINDOW PANEL ASSY			
INDEX NO.	DESCRIPTION	MATERIAL OR MODEL NUMBER	PART NUMBER	REQ'D NUMBER							
				K-1 A-2	A-3 B-0	B-1					
1	WIND FRAME		232648-01	1	1	1					
2	WIND PANEL		232649-03	1	1	1					

DETAIL LABEL-TERMINAL

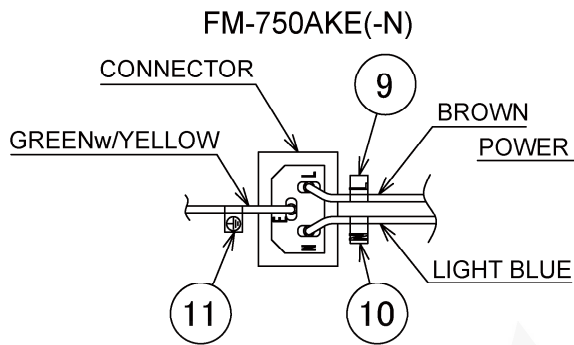

DETAIL LABEL-TERMINAL

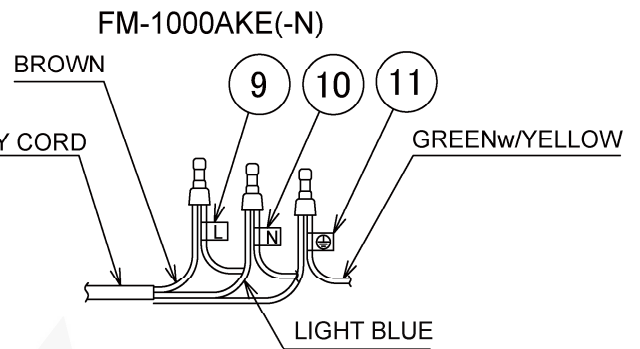

DETAIL CONTROL BOX

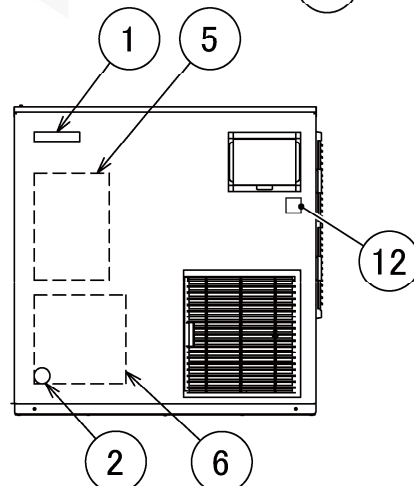
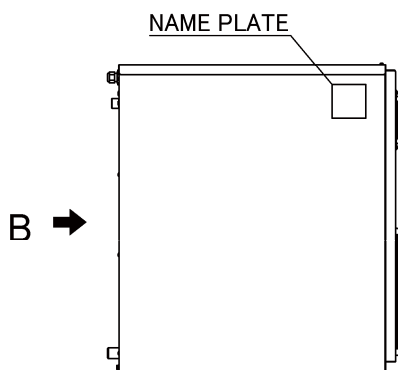
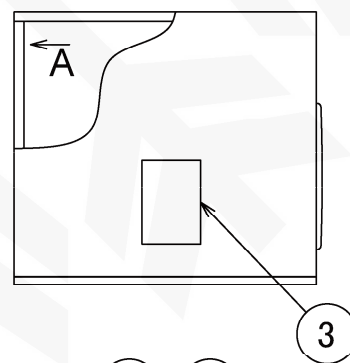
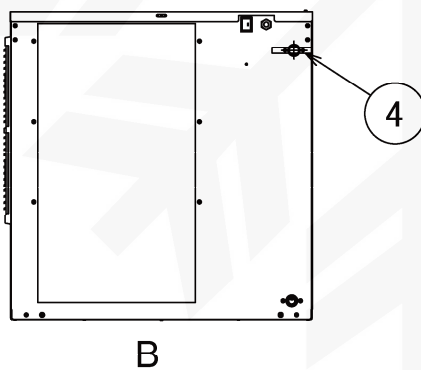
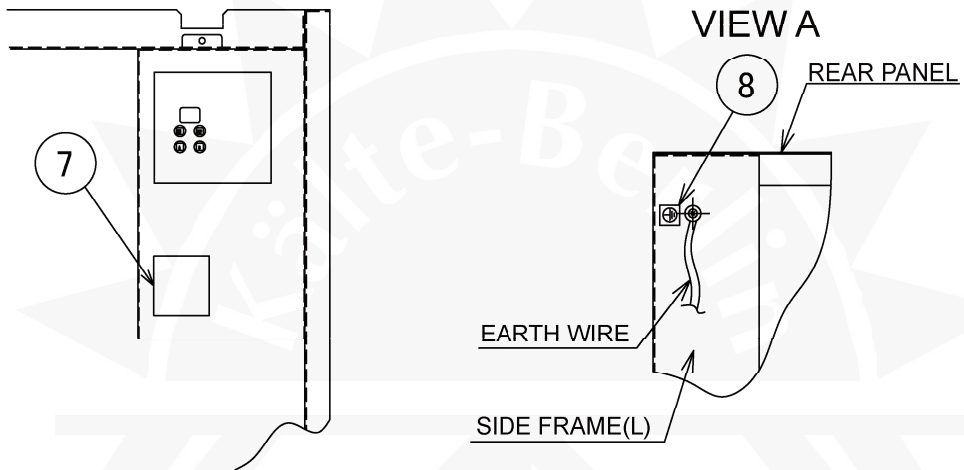

MODEL: FM-750AKE(-N) FM-1000AKE(-N)								TITLE: G. LABEL LOCATION			
INDEX NO.	DESCRIPTION	MATERIAL OR MODEL NUMBER	PART NUMBER	REQ'D NUMBER							
				K-1 A-2	A-3 B-0	B-1					
1	EMBLEM		340842-01	1	1	1					
2	LABEL-PENGUIN		454387-01	1	1	1					
3	INSTRUCTION SHEET		374473L01	1	-	-					
4	CAUTION-LABEL		452552-01	1	1	1					
5	LABEL - ERROR TABLE		259134L01	1	1	1					
6	WIRING LABEL	(F054, F054-C106)	259121L01	1	-	-					
			261350L01		1	1					
		(F055, F055-C106)	259122L01	1	-	-					
			261351L01		1	1					
7	CAUTION LABEL - SERVICE		471180L01	1	1	1					
8	LABEL-GROUND (B)		450452-02	1	1	1					
9	LABEL-TERMINAL		452379-03	1	1	1					
10	LABEL-TERMINAL		452379-04	1	1	1					
11	LABEL-TERMINAL		452379-05	1	1	1					
12	LABEL - HACCP		476519L01	1	1	1					

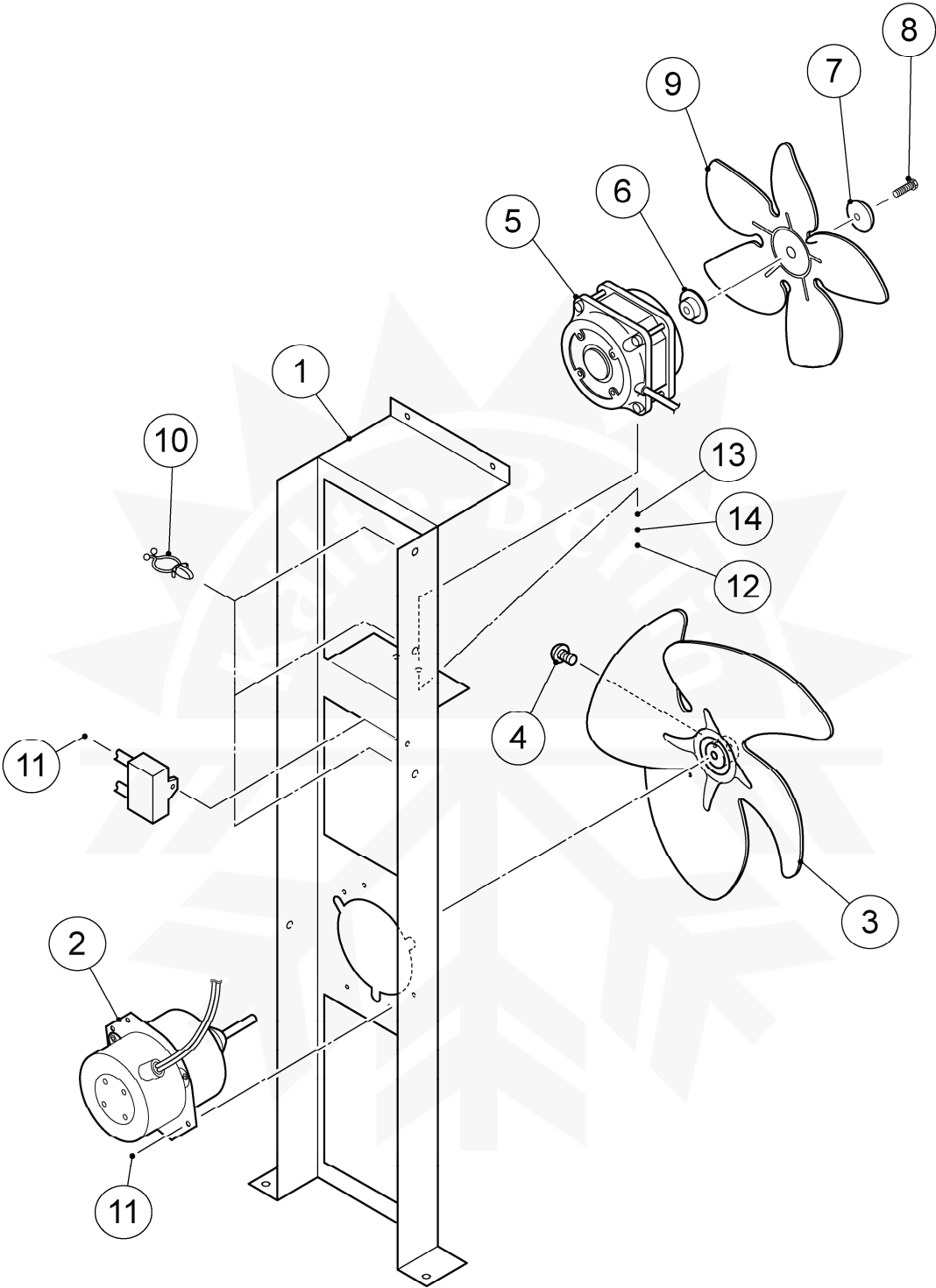

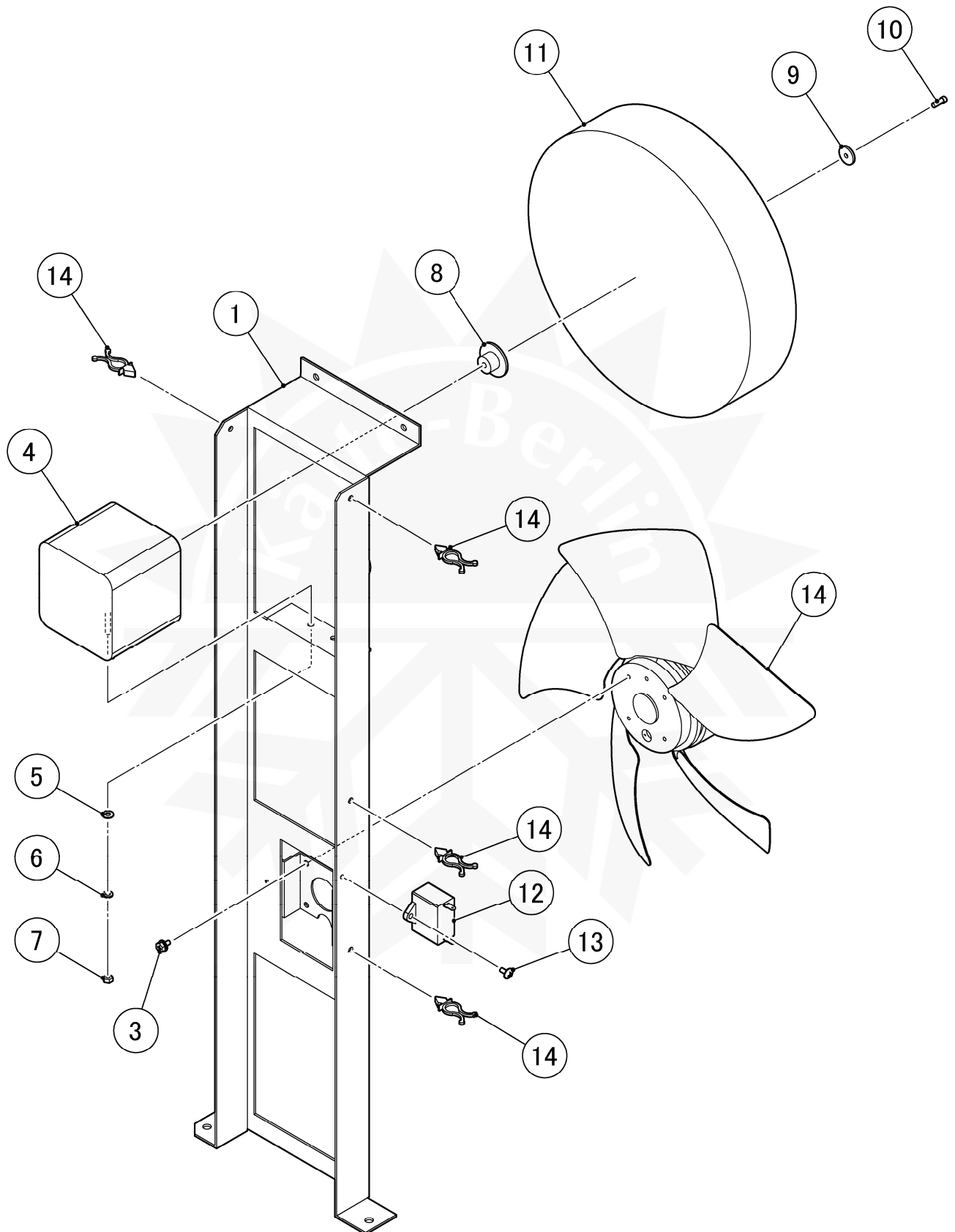

MODEL: FM-750AKE(-N) FM-1000AKE(-N)		TITLE: H. FAN MOTOR ASSY					
INDEX NO.	DESCRIPTION	MATERIAL OR MODEL NUMBER	PART NUMBER	REQ'D NUMBER			
				K-1 A-2	A-3 B-0		
1	BRACKET-FAN MOTOR		241616-01	1	1		
2	FAN MOTOR		4Y2900-01	1	1		
3	FAN BLADE		417068-01	1	1		
4	SCREW		417068F01	1	1		
5	FAN MOTOR		451766-01	1	1		
6	VIBRATION PAD		451766F01	1	1		
7	WASHER/PAD		451766F02	1	1		
8	BOLT		451766F03	1	1		
9	FAN		354246-01	1	1		
10	CLAMP	No.249	427902-03	3	3		
11	PAN HEAD MACHINE SCREW (SPRING WASHER AND FLAT WASHER)		FSK0408S0	5	5		
12	NUT		FNH104S0	2	2		
13	FLAT WASHER		FWPL04S0	2	2		
14	SPRING WASHER		FWSP04S0	2	2		

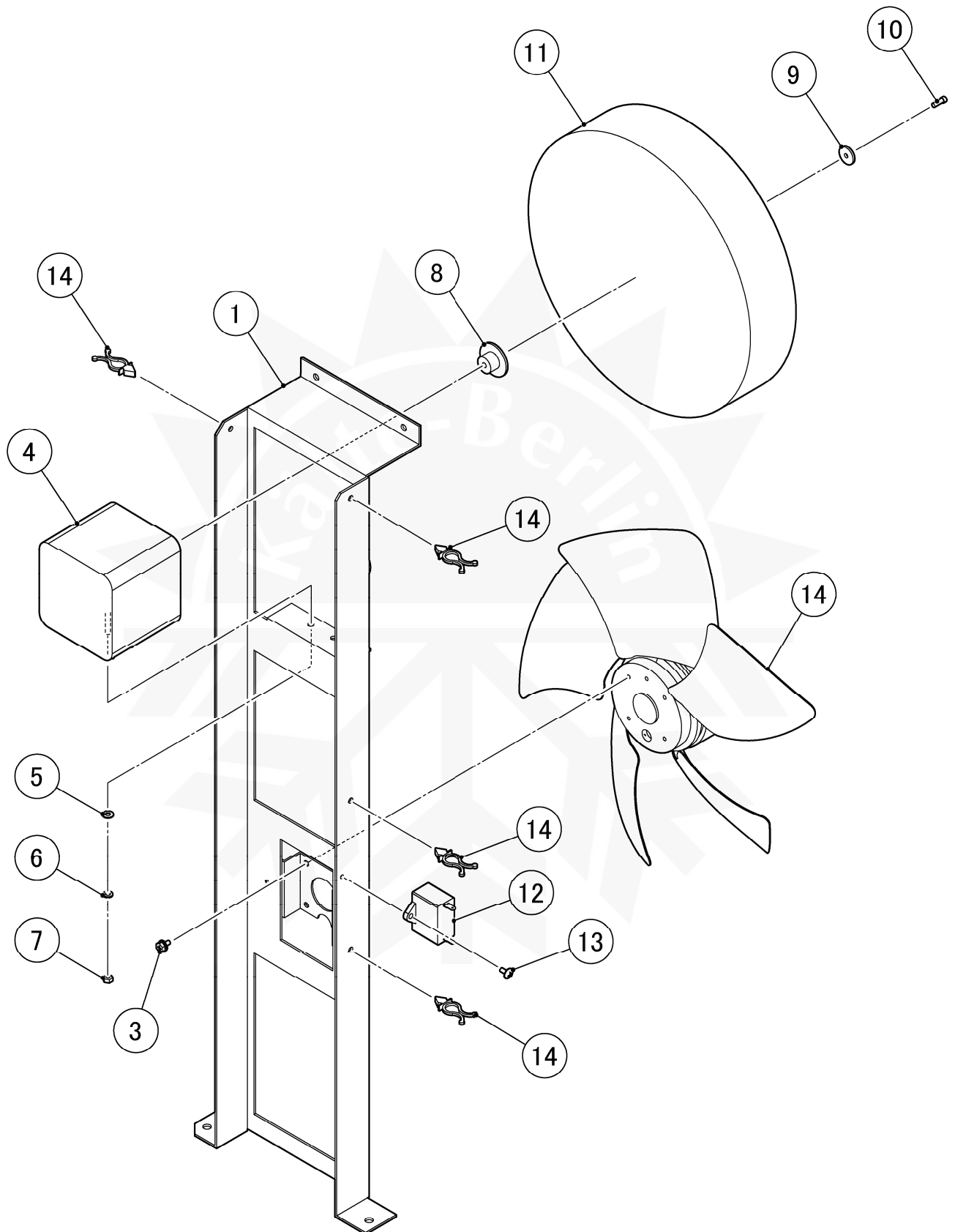

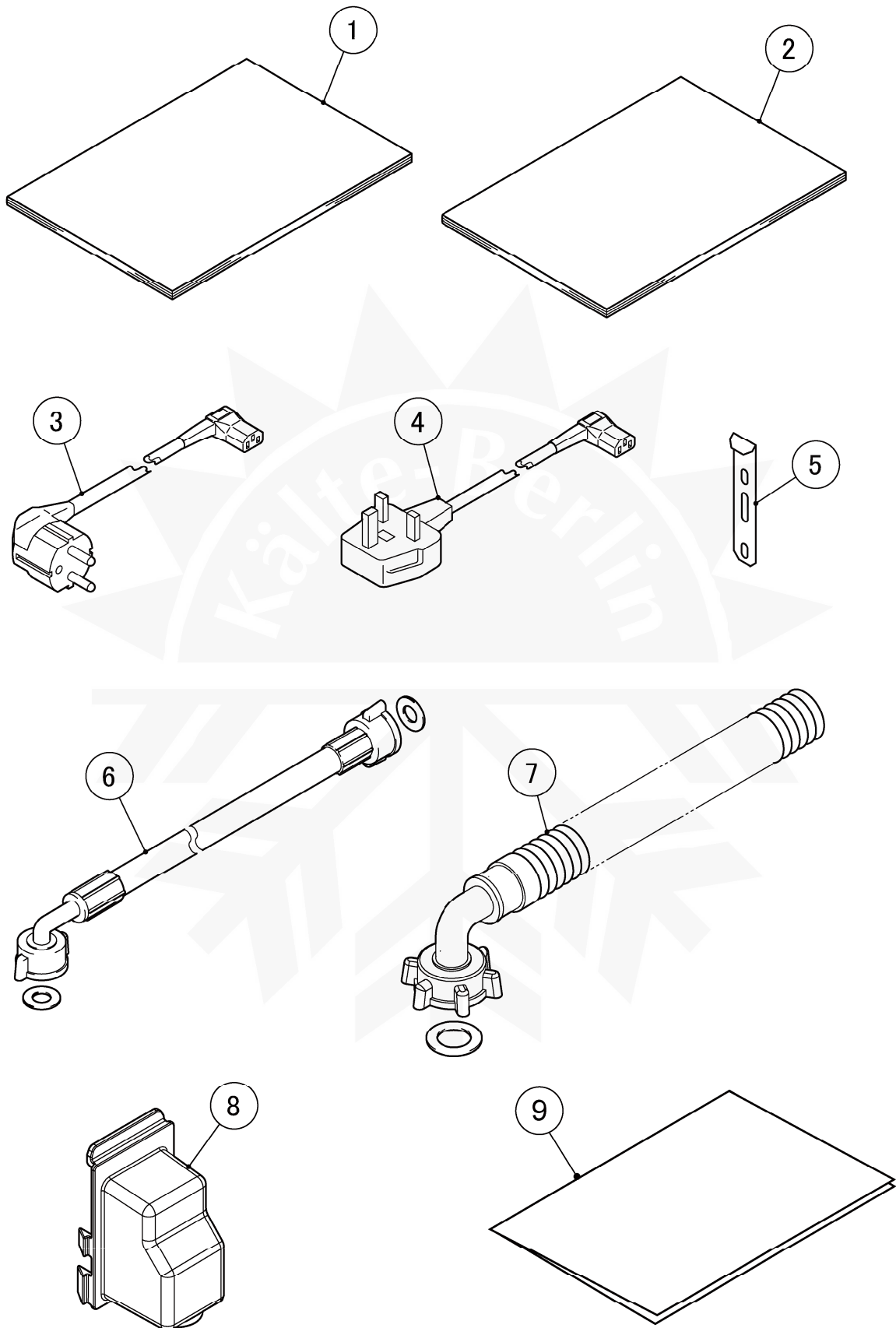

HE

MODEL: FM-750AKE(-N) FM-1000AKE(-N)								TITLE: J. ACCESSORIES							
INDEX NO.	DESCRIPTION	MATERIAL OR MODEL NUMBER	PART NUMBER	REQ'D NUMBER											
				K-1 A-2	A-3 B-0	B-1									
1	INSTRUCTION MANUAL		L1F054202	1	1	1									
2	INSTALLATION MANUAL		L2F054201	1	1	1									
3	POWER CORD	CONT Plug (F054, F054-C106)	P00243-01	1	1	1									
4	POWER CORD	UK Plug (F054, F054-C106)	P00244-01	1	1	1									
5	UNIVERSAL BRACE		4A0363-01	2	2	2									
6	INLET HOSE		450722-01	1	1	1									
7	OUTLET HOSE		452365-01	1	1	1									
8	COVER-CONNECTOR	(F054, F054-C106)	2X0271P01			1									
9	INSTRUCTION MANUAL		122234L01	1	1	1									

(S-9165)

FM-750AKE(-N)
FM-1000AKE(-N)

K. BAND ASSY

(A-3) and later

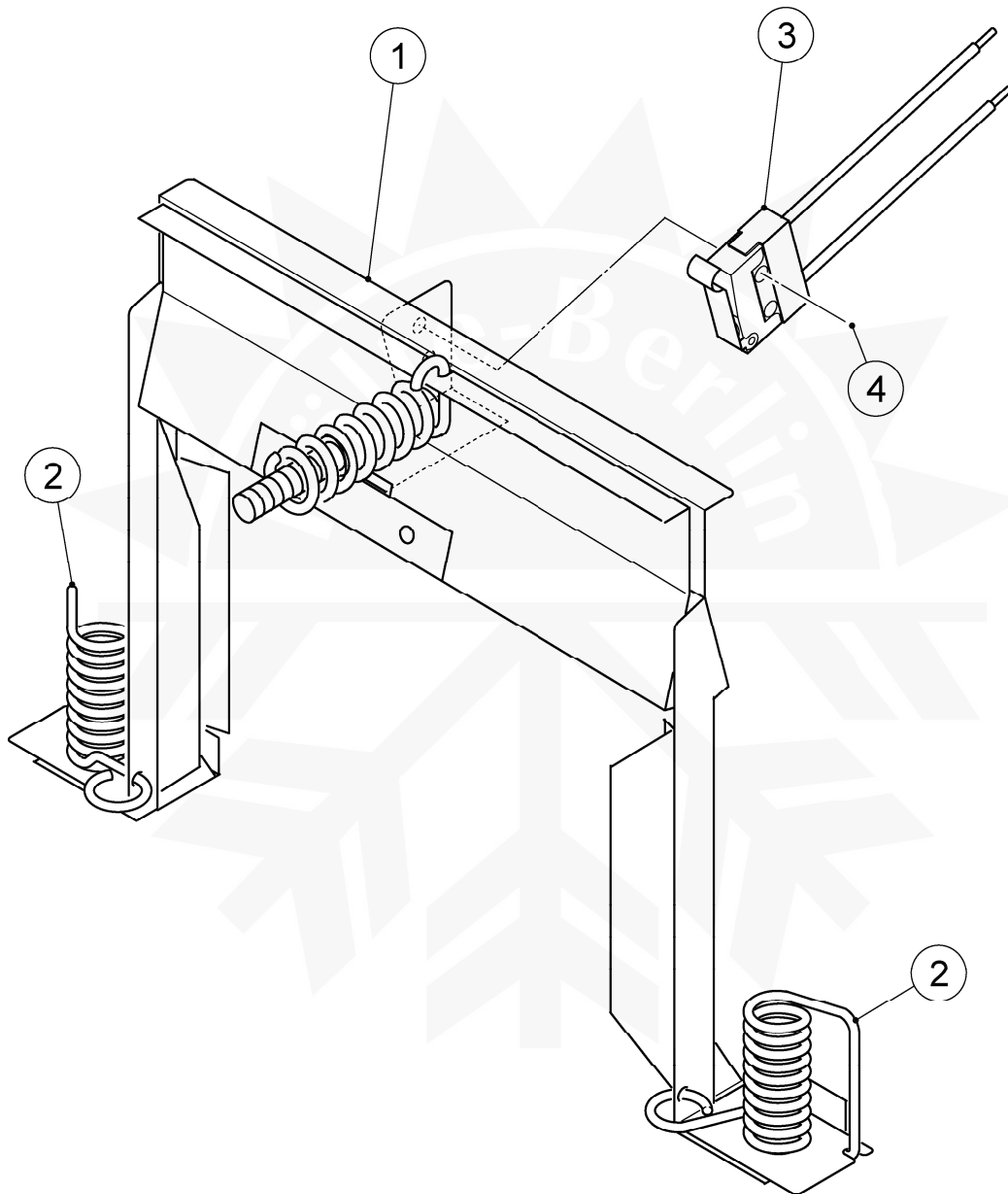

HE

MODEL: FM-750AKE(-N) FM-1000AKE(-N)								TITLE: K. BAND ASSY(S-9165)			
INDEX NO.	DESCRIPTION	MATERIAL OR MODEL NUMBER	PART NUMBER	REQ'D NUMBER							
				A-3 B-0	B-1						
1	BAND (A)		348305G01	1	1						
2	SPRING (A)		459997-01	2	2						
3	MICROSWITCH	ABS1624318	443992-02	1	1						
4	PAN HEAD MACHINE SCREW (SPRING WASHER AND FLAT WASHER)		470416-01	2	2						

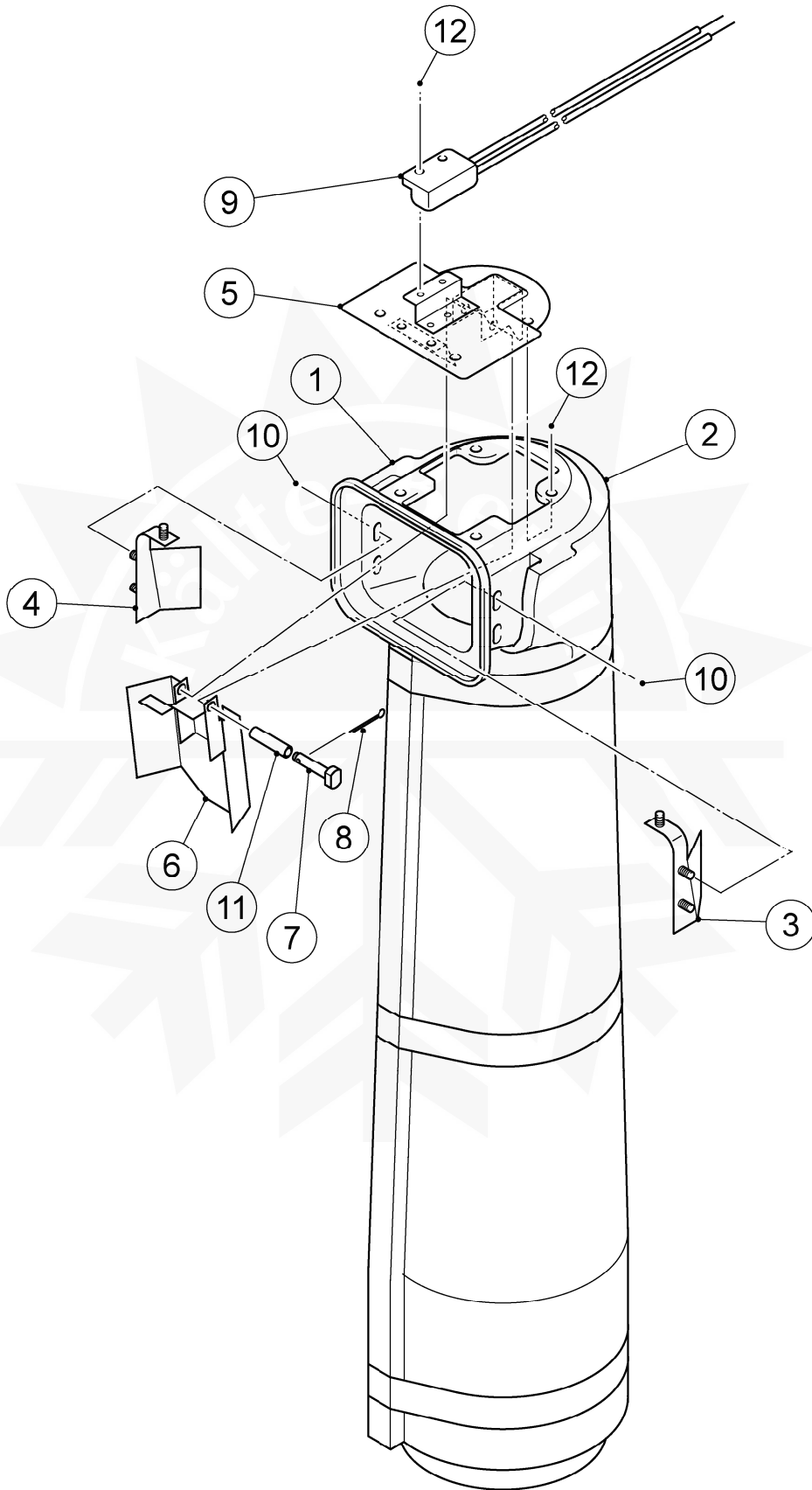

HE

MODEL: **FM-750AKE(-N)**
FM-1000AKE(-N)

TITLE: **L. CHUTE ASSY**

INDEX NO.	DESCRIPTION	MATERIAL OR MODEL NUMBER	PART NUMBER	REQ'D NUMBER			
				A-3 B-0	B-1		
1	CHUTE		214823-01	1	1		
2	INSULATION-CHUTE		235310-01	1	1		
3	BAFFLE - CHUTE (A)		325122G01	1	1		
4	BAFFLE - CHUTE		325123G01	1	1		
5	BIN CONTROL		353918G01	1	1		
6	ACTUATOR		436848G05	1	1		
7	SHAFT		458813-01	1	1		
8	SPLIT PIN		711SP1612	1	1		
9	PROXIMITY SWITCH		4A2033-01	1	1		
10	WING NUT		FNW204S0	6	6		
11	TUBE		461623-01	1	1		
12	TRUSS HEAD MACHINE SCREW		FST0406S0	4	4		