

Sèlç ÈÖ\jã  
Q @XO@a cã Á\i\*  
QF ÁU-ç\ãã Á\Á F  
FCGEJÁÖ\jã  
Q } KÈI JÁEDHÉÁI ÁFÉÁ ÉÁGG  
QãKÈI JÁEDHÉÁI ÁFÉÁ ÉÁGF  
^T ããKã fO \æ\çÈÁ\jã ÈÁ^  
Qç\i ^çKç KQ , , Èæ\çÈÁ\jã ÈË{

Öã\ çã\ÁP\ • @ãããZ\jã á\i^ã á\i^ã\Á FHE T ÖÈÖÁ^ ÁSèlç ÈÖ\jã

NO.	E1BU-2032
ISSUED:	MAY.1998
REVISED:	DEC.2011



# HOSHIZAKI SELF-CONTAINED CUBER

MODEL **IM-130ME**  
**IM-130ME-21**  
**IM-130ME-23**  
**IM-130ME-C**  
**PARTS LIST**

# MATERIAL ABBREVIATIONS

## ALUMINUM

AL = Aluminum

## COPPER

CU = Copper

## PLASTIC

ABS = Acrylonitrile -butadiene - styrene  
AC = Polyacetal  
EVA = Ethylene vinyl acetate  
PA = Polyamide = Nylon  
PC = Polycarbonate  
PE = Polyethylene  
PES = Polyester  
PETP = Polyethylene terephthalate = Tetlon  
PP = Polypropylene  
PS = Polystyrene  
PTFE = Polytetrafluoroethylene = Teflon  
PUR = Polyurethane  
PVC = Polyvinyl chloride

## RUBBER

VN = Vinyl Nitrile  
EPDM = EP rubber  
NBR = Nitrile butadiene rubber  
NR = Natural rubber  
NP = Neoprene  
SI.R = Silicone rubber  
SY.R = Synthetic rubber  
EPH = Epichlorohydrin

## STEEL

GS = Galvanized steel  
SS = Stainless steel  
PS = Plated steel  
PAS = Primed steel

## AUXILIARY CODE

K-0

Designates the year. "K" indicates the year 2000. Years progress or regress in alphabetical order. "J" is 1999, "L" is 2001, "M" is 2002, and so on. The letters "I" and "O" were skipped.

Designates significant part changes within the same year. Base is 0 and this number advances for each change.

Example: P-1

"P" indicates 2004.

"1" indicates the first significant part change for 2004.

## MARKS LOCATED UNDER THE AUXILIARY CODE

- = Part deleted.
- x = Part deleted and replaced by "o" part.
- o = New part in place of "x" part.

## FASTENER ABBREVIATION LIST

ST	=	Phillips Truss Head Machine Screw
SP	=	Phillips Pan Head Machine Screw
SF	=	Phillips Flat Head Machine Screw
SS	=	Phillips Pan Head Machine Screw with Split Lock Washer
SW	=	Phillips Pan Head Machine Screw with Split Lock Washer and Flat Washer
T1	=	Phillips Truss Head Tapping Screw (Correspond to Type A)
T2	=	Phillips Truss Head Tapping Screw (Correspond to Type B)
T3	=	Phillips Truss Head Tapping Screw (Correspond to Type C)
FT	=	Phillips Truss Head Tapping Screw (Special)
BH	=	Hexagon Head Bolt
BC	=	Socket Head Cap Screw
BS	=	Hexagon Bolt with Split Washer
BW	=	Hexagon Bolt with Split Washer and Flat Washer
BF	=	Hexagon Flange Bolt
BR	=	Cross-Recessed Hexagon Head Bolt
BRW	=	Cross-Recessed Hexagon Head Bolt with Split Lock Washer and Flat Washer
WL	=	Split Lock Washer
WT	=	External Tooth Washer
WF	=	Flat Washer
WS	=	Spring Washer
NH	=	Hexagon Nut
NF	=	Hexagon Flange Nut
NC	=	Hexagon Cap Nut
NS	=	Square Nut
NW	=	Wing Nut

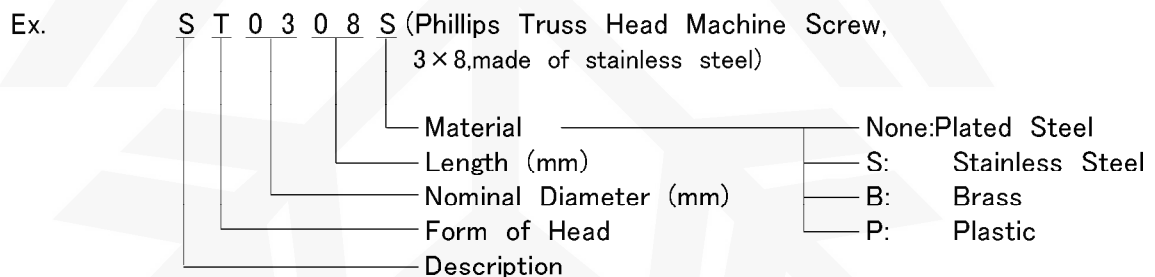

(Note)     Second character is numerical except the list.  
                  Ex: S1,S2,B3 etc.

And abbreviations and names are shown under the illustration.



**HE, GENERAL, RINNAI, OCEANIA, AUSTRALIA, HSP**

MODEL : <b>IM-130ME</b>							
<b>IM-130ME-21,-23</b>				TITLE : <b>A. ICE CUBER ASSY</b>			
INDEX NO.	DESCRIPTION	MATERIAL OR MODEL NUMBER	PART NUMBER	REQ'D NUMBER			
				H-1	H-2 J-0 K-0 A-0 B-0 C-0 D-0	D-1 E-0	E-1 F-0 G-0
B	REFRIGERATION UNIT	(130ME)	1H1763A01	1	—		
			1H1763A02		1	1	1
	REFRIGERATION UNIT	(130ME-21, -23)	-	1	1	1	1
C	ICE MAKING MECHANISM ASSY	(130ME)	1H0268A06	1	1	1	1
	ICE MAKING MECHANISM ASSY	(130ME-21, -23)	-	1	1	1	1
D	CONTROL BOX ASSY	-	2H3668A01	1	1	—	
			2H3668A04			1	—
			2H6792A01				1
E	DOOR ASSY	-	3H1420A07	1	1	1	1
			3Y2909A01				
			3Y3817A01				
F	WATER CIRCUIT ASSY	-	3H9588A01	1	1	1	1
G	LABEL LOCATION	(130ME)	3X1600A01	1	1	1	—
			3X1600A03				1
		(130ME-21, -23)	-	1	1	1	1
1	UNIT BODY	-	1H1259G01	1	1	1	1
			1H1259G03				
2	FRONT PANEL (UPPER)	(HE) (GENERAL) (OCEANIA) (AUSTRALIA) (HSP)	3H8109G04	1	1	1	1
	FRONT PANEL (UPPER)	(RINNAI)	3H8109G08	1	1	×	
3	HINGE (RIGHT)	S.S	4H2583-01	1	1	1	1
4	HINGE (LEFT)	S.S	4H2584-01	1	1	1	1
5	TOP PANEL	S.S	3H9607-01	1	1	1	1
6	FRONT PANEL (LOWER)	S.S	2H3240-01	1	1	1	1
7	LOUVER	ABS	101812-09	1	1	1	1
8	SEAL	TP-230, t3 x 15 x 700	1H1761-44	1	1	1	1
9	FRONT FRAME	S.S	3H7761-04	1	1	1	1
10	INSULATION - FRONT FRAME	PE	4H2687-01	1	1	1	1
11	COVER - PIPE	G.S	3H1436-01	1	1	1	1
12	DRAIN PAN	ABS	2H1935-01	1	1	1	1

**HE, GENERAL, RINNAI, OCEANIA, AUSTRALIA, HSP, CHINA**

MODEL : IM-130ME, IM-130ME-21 IM-130ME-23, IM-130ME-C								TITLE: A. ICE CUBER ASSY			
INDEX NO.	DESCRIPTION	MATERIAL OR MODEL NUMBER	PART NUMBER	REQ'D NUMBER							
				G-1	G-2 T-0	T-1,U-0 V-0,L-0					
B	REFRIGERATION UNIT	(130ME)	1H1763A02	1	1	1					
		(130ME-21, -23)	-	1	1	1					
		(130ME-C)	-			1					
C	ICE MAKING MECHANISM ASSY	(130ME)	1H0268A06	1	1	1					
		(130ME-21, -23)	-	1	1	1					
		(130ME-C)	-			1					
D	CONTROL BOX ASSY	-	2H6792A01	1	1	1					
E	DOOR ASSY	-	3H1420A07	1	—						
		-	3Y2909A01		1	—					
		-	3Y3817A01			1					
F	WATER CIRCUIT ASSY	-	3H9588A01	1	1	1					
G	LABEL LOCATION	(130ME)	3X1600A03	1	1	1					
		(130ME-21, -23)	-	1	1	1					
		(130ME-C)	-			1					
1	UNIT BODY	-	1H1259G01	—							
		-	1H1259G03	1	1	1					
2	FRONT PANEL (UPPER)	-	3H8109G04	1	1	1					
	FRONT PANEL (UPPER)	-	-								
3	HINGE (RIGHT)	S.S	4H2583-01	1	1	1					
4	HINGE (LEFT)	S.S	4H2584-01	1	1	1					
5	TOP PANEL	S.S	3H9607-01	1	1	1					
6	FRONT PANEL (LOWER)	S.S	2H3240-01	1	1	1					
7	LOUVER	ABS	101812-09	1	1	1					
8	SEAL	TP-230, t3 x 15 x 700	1H1761-44	1	1	1					
9	FRONT FRAME	S.S	3H7761-04	1	1	1					
10	INSULATION - FRONT FRAME	PE	4H2687-01	1	1	1					
11	COVER - PIPE	G.S	3H1436-01	1	1	1					
12	DRAIN PAN	ABS	2H1935-01	1	1	1					
13	PIPE - DRAIN	ABS	4H2688-01	1	1	1					
14	DRAIN TUBE	SI	4H2585-01	1	1	1					
15	SLOPE	ABS	3H1452G01	1	1	1					
16	TAPER COLLAR	S.S	4H0171-01	4	4	4					
17	AIR FILTER	PP	208284G02	2	2	2					



**HE, GENERAL, RINNAI, OCEANIA, AUSTRALIA, HSP, CHINA**

MODEL : IM-130ME, IM-130ME-21 IM-130ME-23, IM-130ME-C								TITLE: A. ICE CUBER ASSY			
INDEX NO.	DESCRIPTION	MATERIAL OR MODEL NUMBER	PART NUMBER	REQ'D NUMBER							
				G-1	G-2 T-0	T-1,U-0 V-0,L-0					
18	HOOK	S.S	4H2685-01	1	1	1					
19	SPRING	ZINC-PLATED WIRE	4H0823-01	1	1	1					
20	CORD BUSHING	CEE-SR-6P-10	448949-01	×							
21	REAR PANEL	S.S	3H9610-01	1	1	1					
22	INSULATION (A)	PE	4H2683-01	1	1	1					
23	INSULATION (B)	PE	4X5297-01	1	1	1					
24	POWER SUPPLY CORD (CONTINENTAL)	(HE)	452263-01	×							
	POWER SUPPLY CORD (UK)	(HE) (HSP, IM-130ME) (HSP, IM-130ME-23)	4X3521G01	×							
	POWER CORD	(GENERAL) (OCEANIA)	4X3520G01	×							
	POWER CORD	(RINNAI) (AUSTRALIA) (HSP, IM-130ME-21)	458139-01	×							
25	-	-	-								
26	-	-	-								
27	INSULATION - TOP PANEL	-	3H9602-01	1	1	1					
28	CONNECTOR	-	P00245-01	1	1	1					
29	POWER CORD	(CONTINENTAL)	P00240-01	1	1	1					
	POWER CORD (WITH UK PLUG)	(UK)	P00241-01	1	1	1					
	POWER CORD	-	P00242-01	1	1	1					
	POWER CORD	(CHINA)	P01960-01			1					



IM-130ME  
 IM-130ME-21, -23  
 IM-130ME-C

B. REFRIGERATION UNIT

(D-1) (E-0) and later  
 (A-0) (B-0) (C-0) (D-0)  
 (H-1) (H-2) (J-0) (K-0)

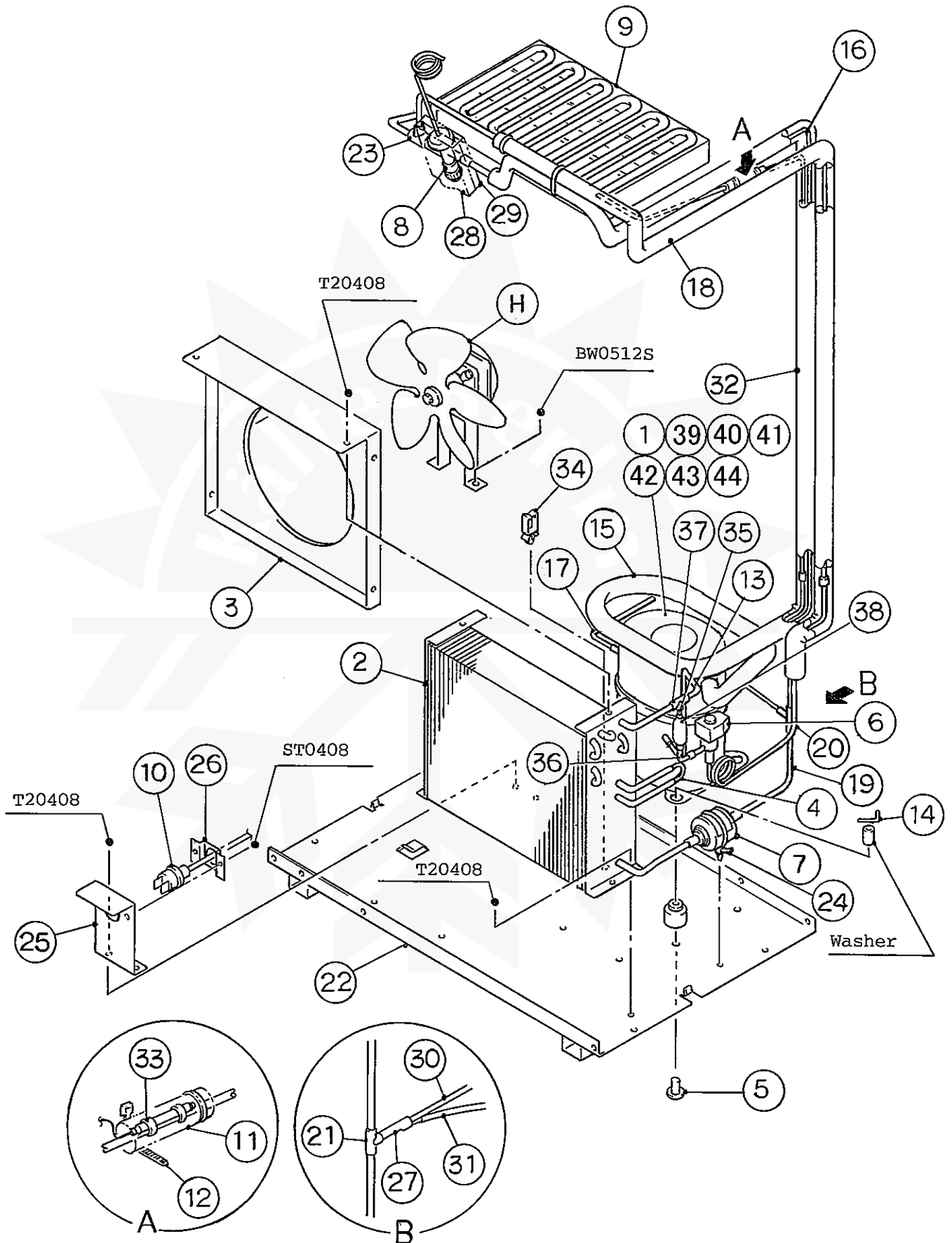

**HE, GENERAL, RINNAI, OCEANIA, AUSTRALIA, HSP**

MODEL : <b>IM-130ME</b>							
<b>IM-130ME-21,-23</b>				TITLE : <b>B. REFRIGERATION UNIT</b>			
INDEX NO.	DESCRIPTION	MATERIAL OR MODEL NUMBER	PART NUMBER	REQ'D NUMBER			
				H-1	H-2 J-0 K-0 A-0 B-0 C-0 D-0	D-1 E-0	E-1 F-0 G-0
H	FAN MOTOR ASSY	(S-0949)	3H9447A01	1	1	1	1
1	COMPRESSOR	SC12DL	454833-01	1	1	1	1
2	CONDENSER	-	2H3292-01	1	1	1	1
3	SHROUD	G.S	3X1508-01	1	1	1	1
4	COPPER TUBE – RETURN	COPPER	4X4045-01	1	1	1	1
5	STEEL PIN	-	452255-01	4	4	4	4
6	HOT GAS VALVE	ATS-7S10HD-1	418636-02	1	1	1	1
7	DRIER	DML032.5S	462965-01	1	1	1	1
8	EXPANSION VALVE	FSE-5NHD-1	454835-01	1	1	1	1
9	EVAPORATOR	(130ME)	2H6438G02	1	1	1	1
	EVAPORATOR	(130ME-21)	2H0716G01	1	1	1	1
	EVAPORATOR (S-0796)	(130ME-23)	2H1836G01	1	1	1	1
10	PRESSURE SWITCH	ACB-1UB09	433441-07	1	1	1	1
11	INSULATION	φ25xφ35xL 130	4X8643-01	1	1	1	1
12	TIE	CV-150	7920-0003	4	4	4	4
13	PIPE (A-1)- HIGH SIDE	COPPER	4X5630-01	1	1	1	1
14	CLIP	-	452256-01	4	4	4	4
15	COPPER TUBE - LOW SIDE	COPPER	4X4044G01	1	—		
		COPPER	4X5817G01		1	1	1
16	HEAT EXCHANGER	-	4X5034G01	1	—		
		-	4X5034G03		1	1	1
17	PROCESS TUBE	COPPER	4X4047-01	1	1	1	1
18	PIPE (A) - HOT GAS	COPPER	4X5716G01	1	1	1	1
19	COPPER TUBE - B	COPPER	4X4243-01	1	—		
		COPPER	4X6099-01		1	1	1
20	PIPE (B) - HOT GAS	COPPER	4X5717-01	1	1	1	1
21	TEE	COPPER	420041-16	1	1	1	1
22	BASE	PAINTED STEEL	3H9601G01	1	1	1	1
		PAINTED STEEL	3Y2586G01				
23	TEE	(130ME-23)	420335-01	1	1	1	1
24	TIE	T50RSF	436156-02	1	1	1	1
25	BRACKET - PRESSURE SWITCH	G.S	4X5631-01	1	1	1	1
26	BRACKET - PRESSURE SWITCH	G.S	425506-01	1	1	1	1
27	TUBE	COPPER	4H9161-01	1	1	1	1

**HE, GENERAL, RINNAI, OCEANIA, AUSTRALIA, HSP, CHINA**

MODEL : IM-130ME, IM-130ME-21 IM-130ME-23, IM-130ME-C								TITLE: B. REFRIGERATION UNIT			
INDEX NO.	DESCRIPTION	MATERIAL OR MODEL NUMBER	PART NUMBER	REQ'D NUMBER							
				G-1	G-2 T-0	T-1,U-0 V-0,L-0					
H	FAN MOTOR ASSY	(S-0949)	3H9447A01	1	1	1					
1	COMPRESSOR	SC12DL	454833-01	1	1	1					
2	CONDENSER	-	2H3292-01	1	1	1					
3	SHROUD	G.S	3X1508-01	1	1	1					
4	COPPER TUBE – RETURN	COPPER	4X4045-01	1	1	1					
5	STEEL PIN	-	452255-01	4	4	4					
6	HOT GAS VALVE	ATS-7S10HD-1	418636-02	1	1	1					
7	DRIER	DML032.5S	462965-01	1	1	1					
8	EXPANSION VALVE	FSE-5NHD-1	454835-01	1	1	1					
9	EVAPORATOR	(130ME)	2H6438G02	1	1	1					
	EVAPORATOR	(130ME-21)	2H0716G01	1	1	1					
	EVAPORATOR (S-0796)	(130ME-23)	2H1836G01	1	1	1					
	EVAPORATOR	(130ME-C)	2X0260G01			1					
10	PRESSURE SWITCH	ACB-1UB09	433441-07	1	1	1					
11	INSULATION	φ25xφ35xL130	4X8643-01	1	1	1					
12	TIE	CV-150	7920-0003	4	4	4					
13	PIPE (A-1)- HIGH SIDE	COPPER	4X5630-01	1	1	1					
14	CLIP	-	452256-01	4	4	4					
15	COPPER TUBE - LOW SIDE	-	-								
		COPPER	4X5817G01	1	1	1					
16	HEAT EXCHANGER	-	-								
		-	4X5034G03	1	1	1					
17	PROCESS TUBE	COPPER	4X4047-01	1	1	1					
18	PIPE (A) - HOT GAS	COPPER	4X5716G01	1	1	1					
19	COPPER TUBE - B	-	-								
		COPPER	4X6099-01	1	1	1					
20	PIPE (B) - HOT GAS	COPPER	4X5717-01	1	1	1					
21	TEE	COPPER	420041-16	1	1	1					
22	BASE	PAINTED STEEL	3H9601G01	—							
		PAINTED STEEL	3Y2586G01	1	1	1					
23	TEE	(130ME-23)	420335-01	1	1	1					
24	TIE	T50RSF	436156-02	1	1	1					
25	BRACKET - PRESSURE SWITCH	G.S	4X5631-01	1	1	1					
26	BRACKET - PRESSURE SWITCH	G.S	425506-01	1	1	1					





IM-130ME  
 IM-130ME-21, -23  
 IM-130ME-C

C. ICE MAKING MECHANISM ASSY

(D-1) (E-0) (E-1) and later  
 (A-0) (B-0) (C-0) (D-0)  
 (H-1) (H-2) (J-0) (K-0)

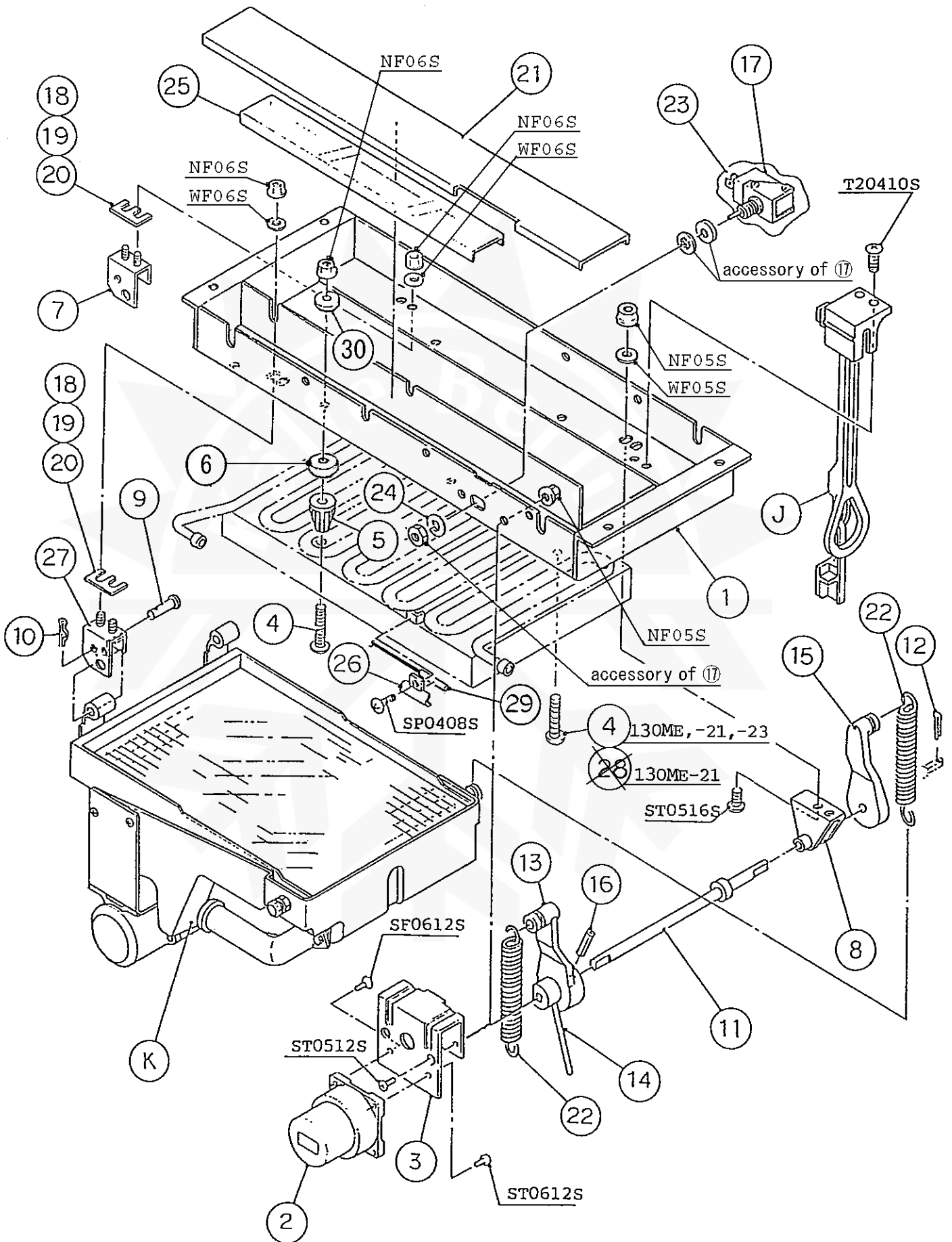

**HE, GENERAL, RINNAI, OCEANIA, AUSTRALIA, HSP**

MODEL : <b>IM-130ME</b>							
IM-130ME-21,-23				TITLE : <b>C. ICE MAKING MECHANISM ASSY</b>			
INDEX NO.	DESCRIPTION	MATERIAL OR MODEL NUMBER	PART NUMBER	REQ'D NUMBER			
				H-1	H-2 J-0 K-0 A-0 B-0 C-0 D-0	D-1 E-0	E-1 F-0 G-0
J	BIN CONTROL SWITCH ASSY	(S-0819)	3H1538A02	1	1	1	1
K	WATER PAN ASSY	(130ME, -23)	2H0679A03	1	1	1	1
	WATER PAN ASSY	(130ME-21)	2H0679A07	1	1	1	1
1	BRACKET - ICEMAKING MECHANISM	(130ME, -23)	3H9594-01	1	1	1	1
	BRACKET - ICEMAKING MECHANISM	(130ME-21)	3X0254-01	1	1	1	1
2	ACTUATOR MOTOR	SR65A41-13	452499-01	1	1	1	1
3	BRACKET - ACTUATOR MOTOR	PAINTED STEEL	4H2679-01	1	1	1	1
4	BOLT - EVAPORATOR MOUNTING	(130ME)	4H2678-01	4	4	4	4
	BOLT - EVAPORATOR MOUNTING	(130ME-21)	4H2886-01	2	2	2	2
	BOLT - EVAPORATOR MOUNTING	(130ME-23)	4H2886-01	4	4	4	4
5	COLLAR		3H3879-01	4	4	4	4
6	WASHER	(130ME-21)	4H1365-06	4	4	4	4
		(130ME-23)	4H1365-05	4	4	4	4
7	BEARING PLATE	S.S	3H1440G04	1	1	1	1
8	BEARING - CAM SHAFT	POM	3X8307-01	1	1	1	1
9	SHAFT (B)	S.S	4H1184-02	2	2	2	2
10	SNAP PIN	S.S, No.6	715S-0600	2	2	2	2
11	CAM SHAFT	S.S	4H2702G01	1	1	1	1
12	SPLIT PIN	S.S, 2x12	711S-0212	1	1	1	1
13	CAM (A)	(303881A02)	306543G02	1	1	1	1
14	CHANGE LEVER	S.S	406261-01	1	1	1	1
15	CAM (B)	AC	315775-01	1	1	1	1
16	SPRING PIN	S.S, 3x28	712S-0328	1	1	1	1
17	TOGGLE SWITCH	VAT4-71	431977-01	1	1	1	1
18	SHIM (A) - EVAPORATOR	S.S	4H2691-01	REQ'D	REQ'D	REQ'D	REQ'D
19	SHIM (B) - EVAPORATOR	S.S	4H2691-02	REQ'D	REQ'D	REQ'D	REQ'D
20	SHIM (C) - EVAPORATOR	S.S	4H2691-03	REQ'D	REQ'D	REQ'D	REQ'D
21	COVER-MECHANISM BASE	PVC	4H2681-01	1	1	1	1
22	SPRING	S.S	4H0287-01	2	2	2	2
23	COVER - THERMISTOR	PE	408163-01	1	1	1	1
24	WASHER - TOGGLE SWITCH	S.S	406196-01	1	1	1	1
25	GUIDE - CONNECTOR	PVC	4H5619-01	1	1	1	1
26	HOLDER - THERMISTOR	PE	3H9642-01	1	1	1	1

**HE, GENERAL, RINNAI, OCEANIA, AUSTRALIA, HSP, CHINA**

MODEL : IM-130ME, IM-130ME-21 IM-130ME-23, IM-130ME-C TITLE : C. ICE MAKING MECHANISM ASSY							
INDEX NO.	DESCRIPTION	MATERIAL OR MODEL NUMBER	PART NUMBER	REQ'D NUMBER			
				G-1	G-2 T-0	T-1,U-0 V-0,L-0	
J	BIN CONTROL SWITCH ASSY	(S-0819)	3H1538A02	1	1	1	
K	WATER PAN ASSY	(130ME, -23)	2H0679A03	1	1	1	
		(130ME-21)	2H0679A07	1	1	1	
		(130ME-C)	1H4751A01			1	
1	BRACKET - ICEMAKING MECHANISM	(130ME, -23)	3H9594-01	1	1	1	
	BRACKET - ICEMAKING MECHANISM	(130ME-21)	3X0254-01	1	1	1	
	MECHANISM BASE	(130ME-C)	2X0249M01			1	
2	ACTUATOR MOTOR	SR65A41-13	452499-01	1	1	1	
3	BRACKET - ACTUATOR MOTOR	PAINTED STEEL	4H2679-01	1	1	1	
4	BOLT - EVAPORATOR MOUNTING	(130ME)	4H2678-01	4	4	×4	
	SCREW EVAPORATOR		4Y4922M02			○4	
	BOLT - EVAPORATOR MOUNTING	(130ME-21)	4H2886-01	2	2	×2	
	SCREW EVAPORATOR		4Y4922M03			○4	
	BOLT - EVAPORATOR MOUNTING	(130ME-23)	4H2886-01	4	4	×4	
	SCREW EVAPORATOR		4Y4922M03			○4	
	SCREW EVAPORATOR	(130ME-C)	4Y4922M01			4	
5	COLLAR	(130ME)	3H3879-01	4	4	4	
6	WASHER	(130ME-21)	4H1365-06	4	4	4	
		(130ME-23)	4H1365-05	4	4	4	
	SPACER	(130ME-C)	4H0471-01			4	
7	BEARING PLATE	(130ME, -23) (130ME-21)	3H1440G04	1	1	1	
	BEARING/WATER PAN	(130ME-C)	3Y5036G01			1	
8	BEARING - CAM SHAFT	POM	3X8307-01	1	1	1	
9	SHAFT (B)	S.S	4H1184-02	2	2	2	
	SHAFT (A)	(130ME-C)	4H1184-01			2	
10	SNAP PIN	S.S, No.6	715S-0600	2	2	2	
11	CAM SHAFT	S.S	4H2702G01	1	1	1	
12	SPLIT PIN	S.S, 2x12	711S-0212	1	1	1	
13	CAM (A)	(303881A02)	306543G02	1	1	1	
14	CHANGE LEVER	S.S	406261-01	1	1	1	
15	CAM (B)	AC	315775-01	1	1	1	
16	SPRING PIN	S.S, 3x28	712S-0328	1	1	1	
17	TOGGLE SWITCH	VAT4-71	431977-01	1	1	1	







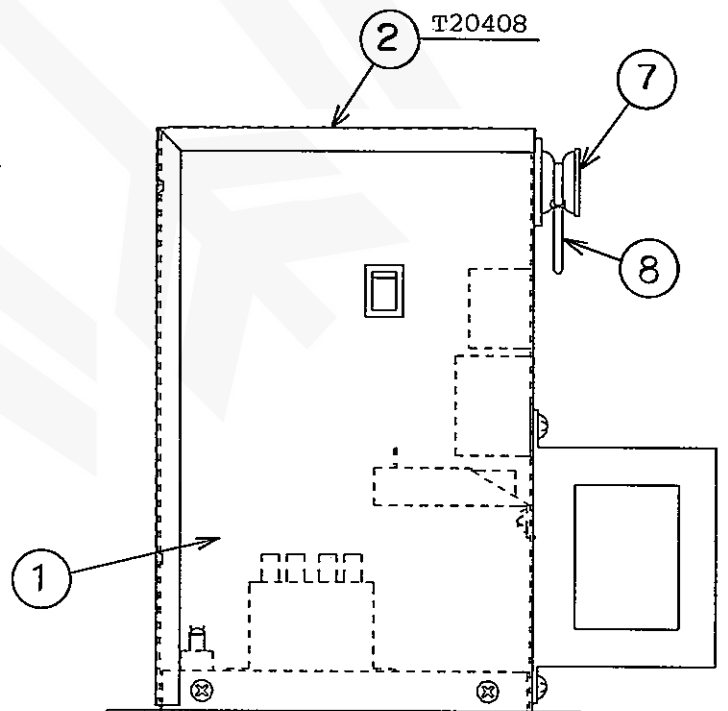
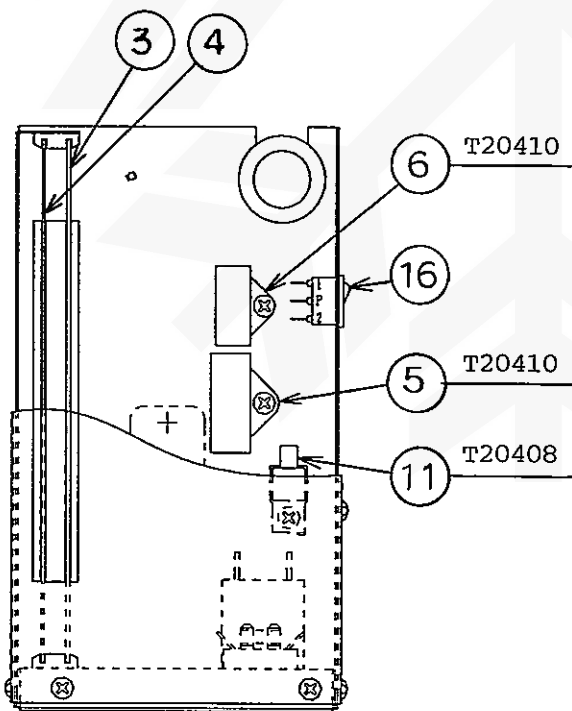
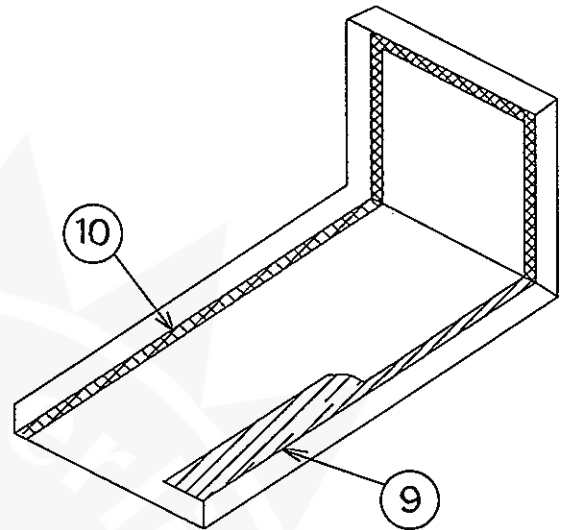
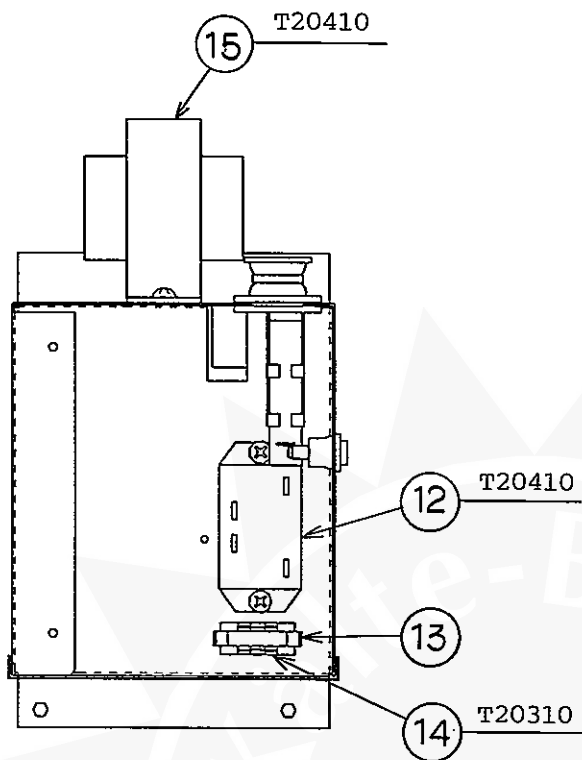

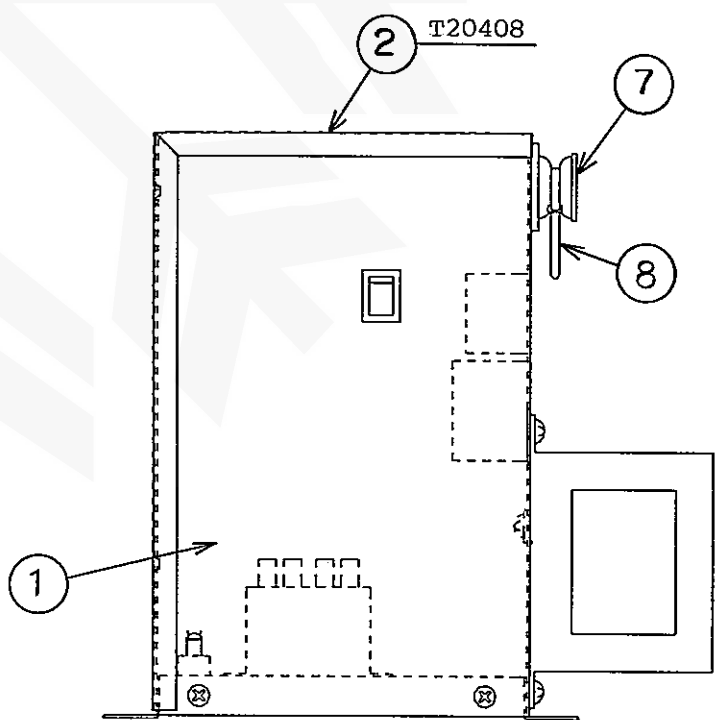
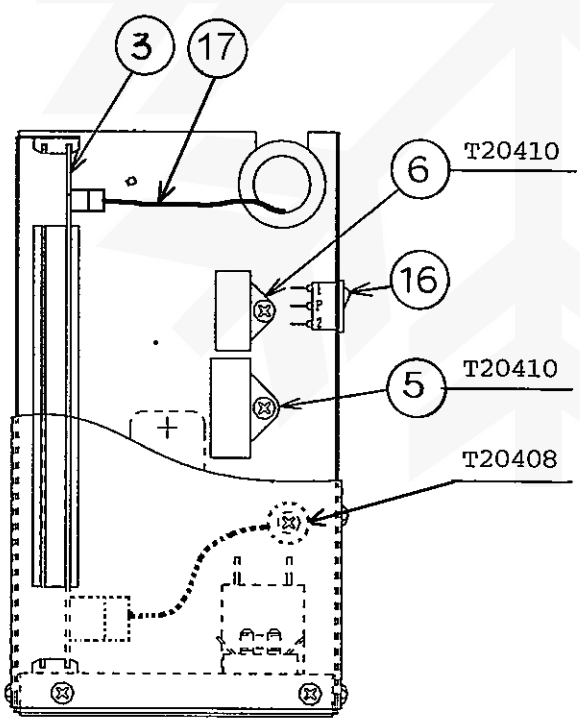
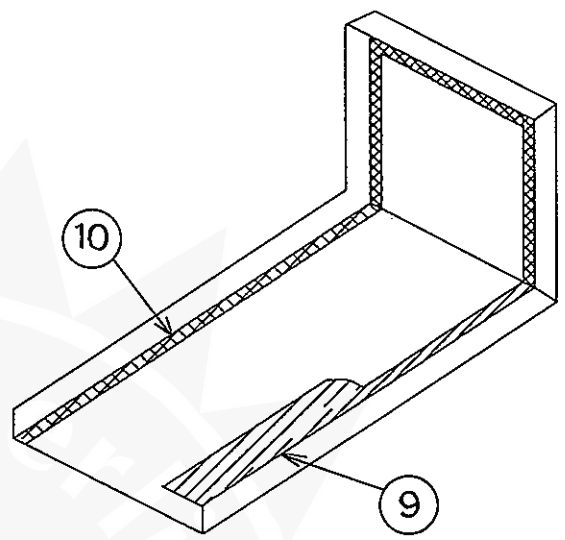
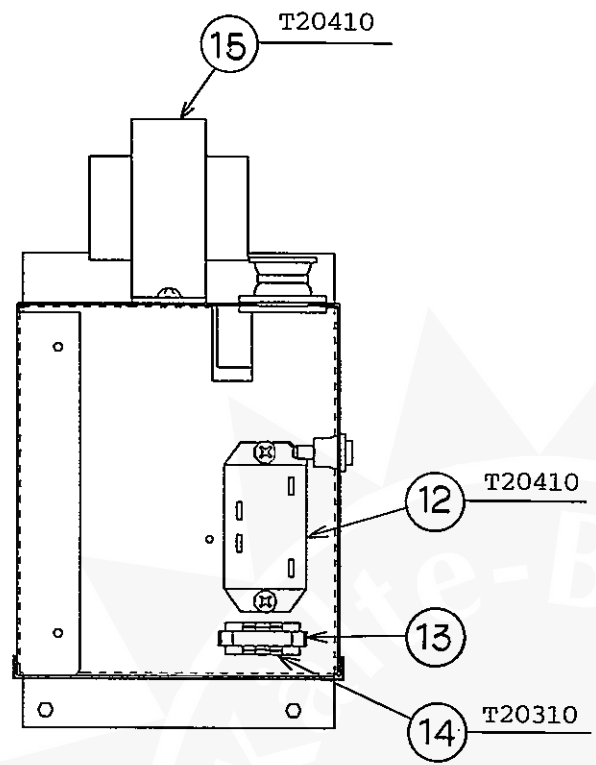





IM-130ME  
IM-130ME-21,-23

E. DOOR ASSY

(G-0) (G-1)  
(D-1) (E-0) (E-1) (F-0)  
(A-0) (B-0) (C-0) (D-0)  
(H-1) (H-2) (J-0) (K-0)

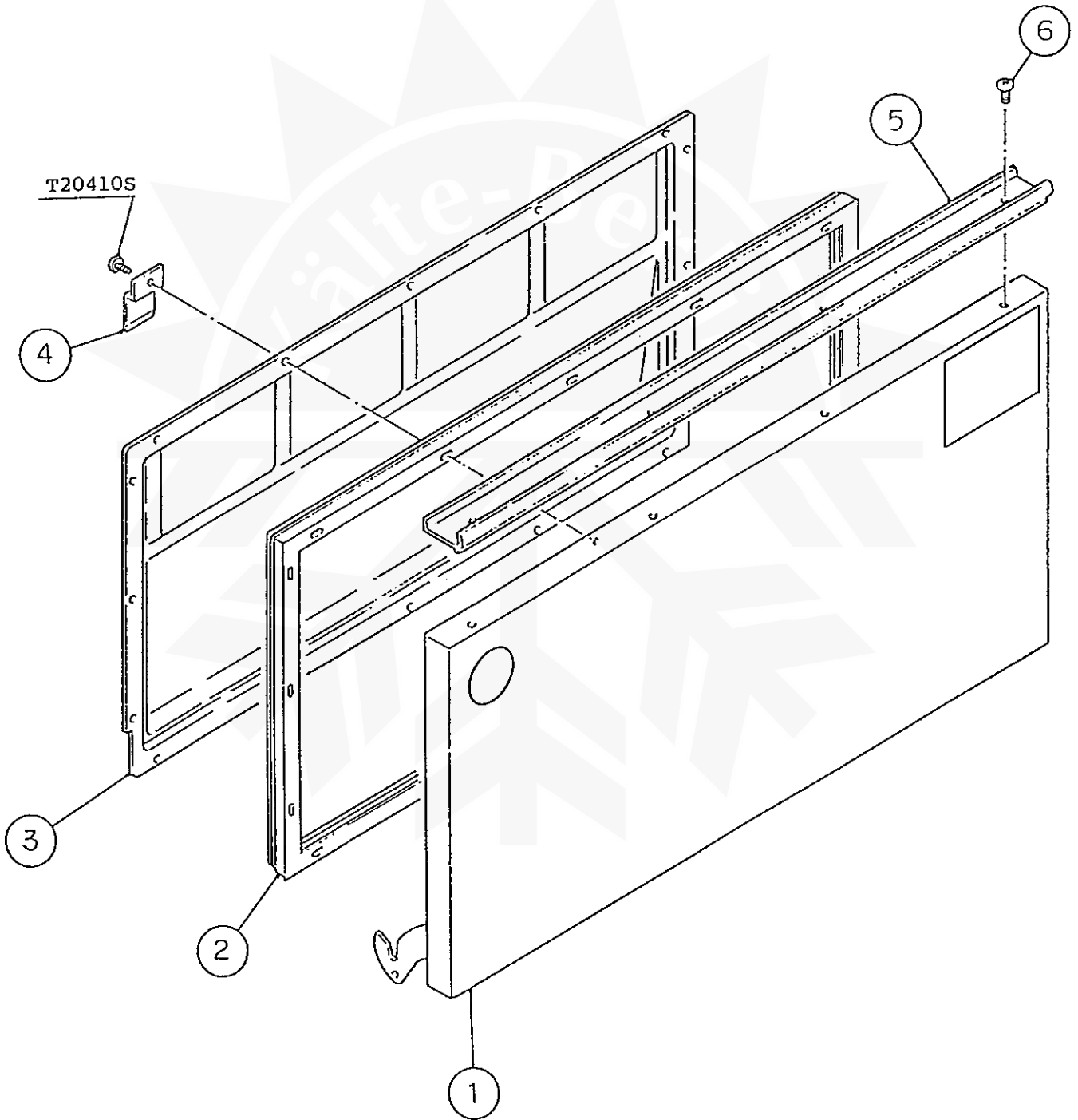

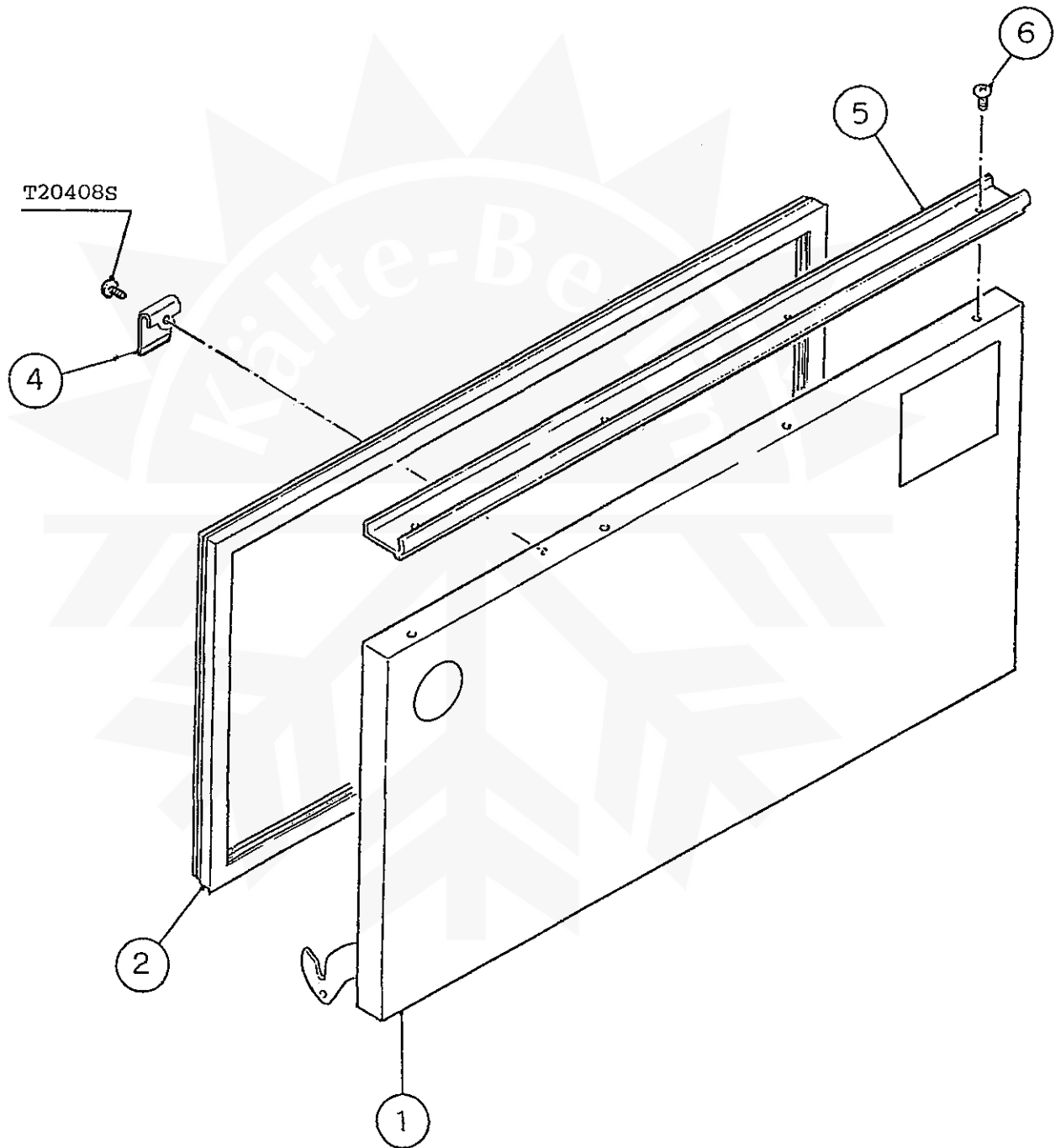



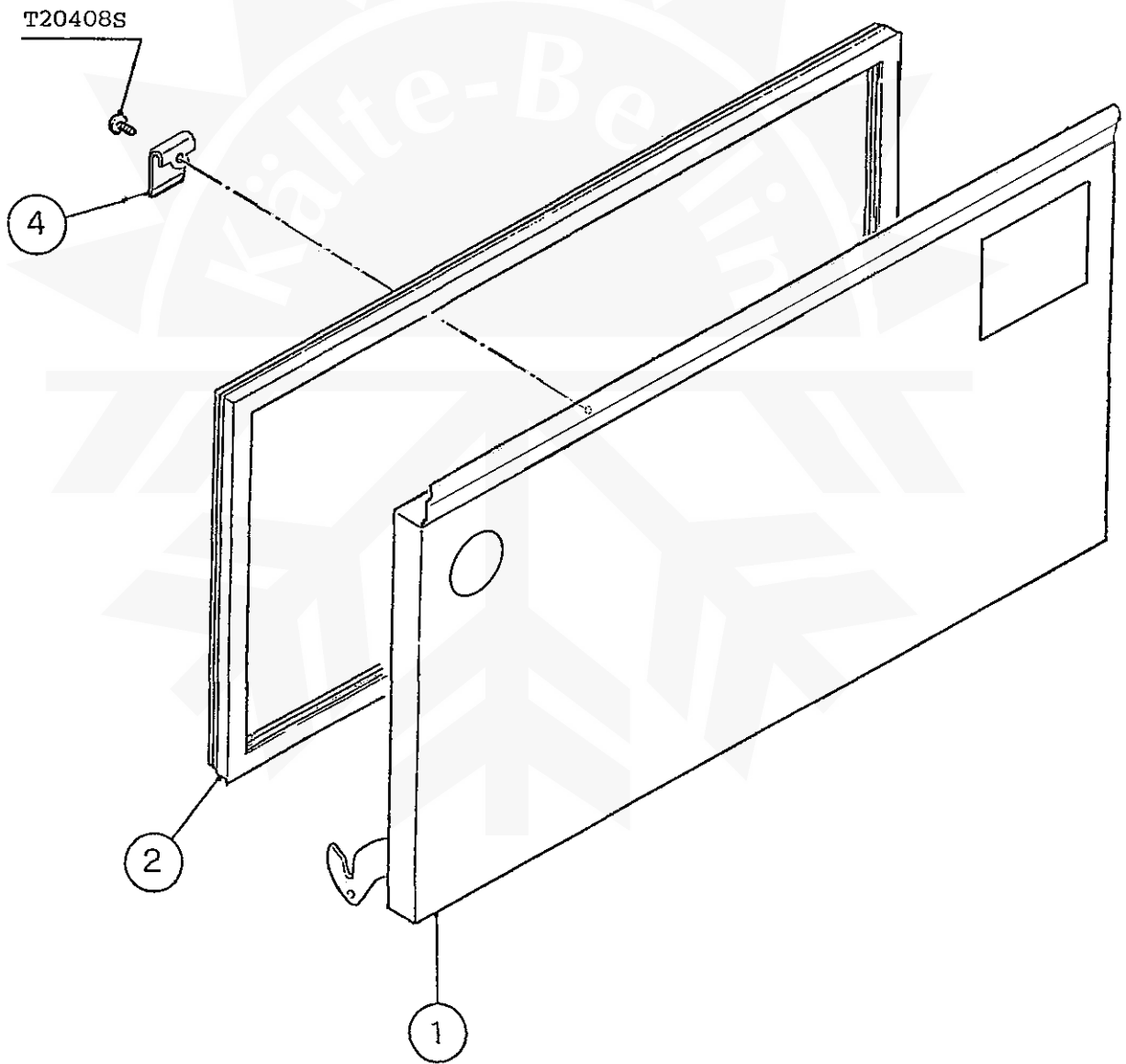





IM-130ME  
IM-130ME-21, -23  
IM-130ME-C

F. WATER CIRCUIT ASSY

(D-1) (E-0) (E-1) and later  
(A-0) (B-0) (C-0) (D-0)  
(H-1) (H-2) (J-0) (K-0)

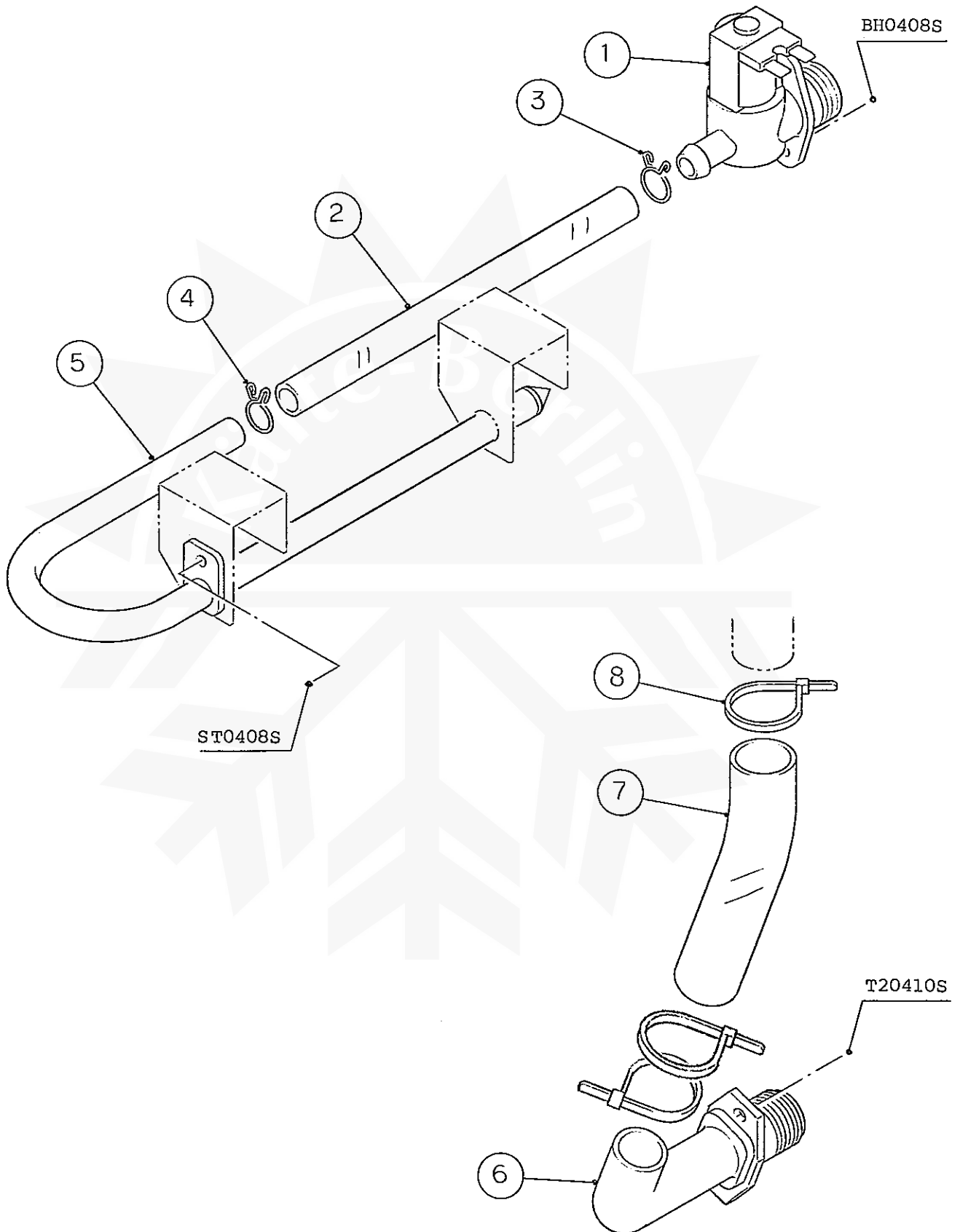





IM-130ME  
IM-130ME-21, -23  
IM-130ME-C

G. LABEL LOCATION

(D-1) (E-0) (E-1) and later  
(A-0) (B-0) (C-0) (D-0)  
(H-1) (H-2) (J-0) (K-0)

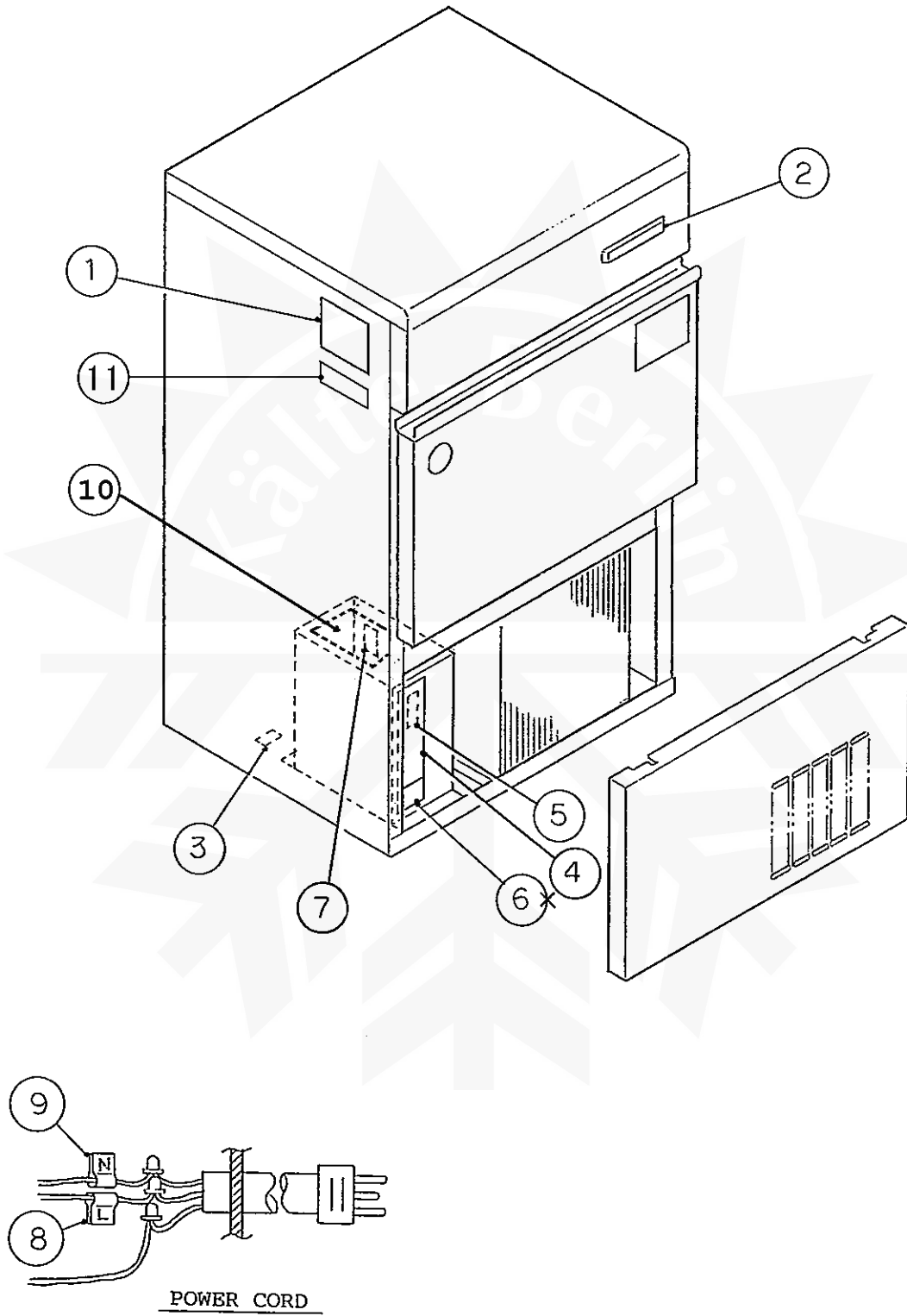







IM-130ME  
IM-130ME-21, -23  
IM-130ME-C

H. FAN MOTOR ASSY

(D-1) (E-0) (E-1) and later  
(A-0) (B-0) (C-0) (D-0)  
(H-1) (H-2) (J-0) (K-0)

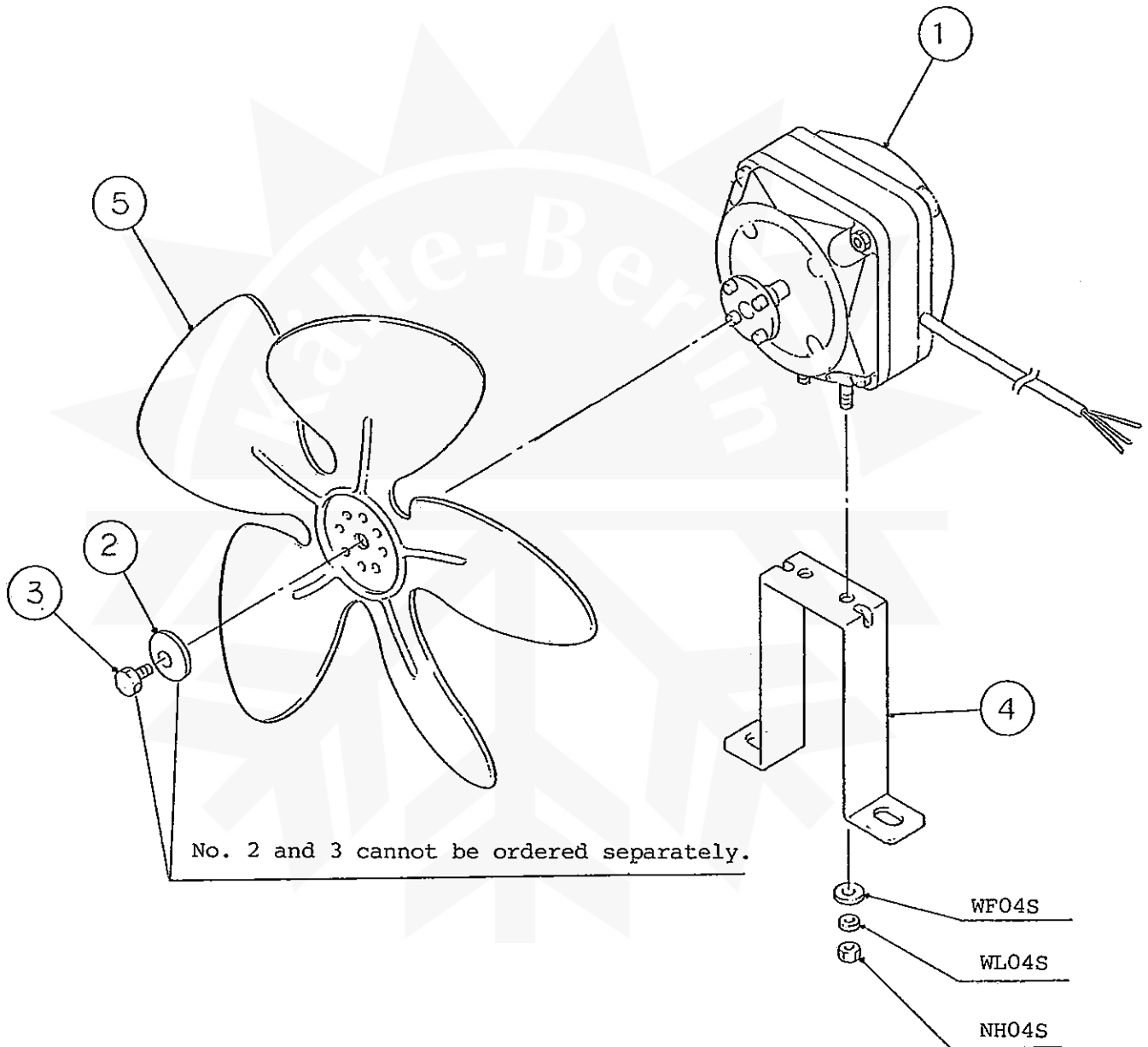

**HE, GENERAL, RINNAI, OCEANIA, AUSTRALIA, HSP**

MODEL : IM-130ME							
IM-130ME-21,-23				TITLE : H. FAN MOTOR ASSY			
INDEX NO.	DESCRIPTION	MATERIAL OR MODEL NUMBER	PART NUMBER	REQ'D NUMBER			
				H-1	H-2 J-0 K-0 A-0 B-0 C-0 D-0	D-1 E-0	E-1 F-0 G-0
1	FAN MOTOR	M40045-CA11-51	451766-01	1	1	1	1
2	WASHER - PAD	-	451766F02	1	1	1	1
3	BOLT	-	451766F03	1	1	1	1
4	BRACKET - FAN MOTOR	G.S	4X3928-01	1	1	1	1
5	FAN	-	451771-01	1	1	1	1



IM-130ME  
IM-130ME-21, -23  
IM-130ME-C

J. BIN CONTROL SWITCH ASSY

(D-1) (E-0) (E-1) and later  
(A-0) (B-0) (C-0) (D-0)  
(H-1) (H-2) (J-0) (K-0)

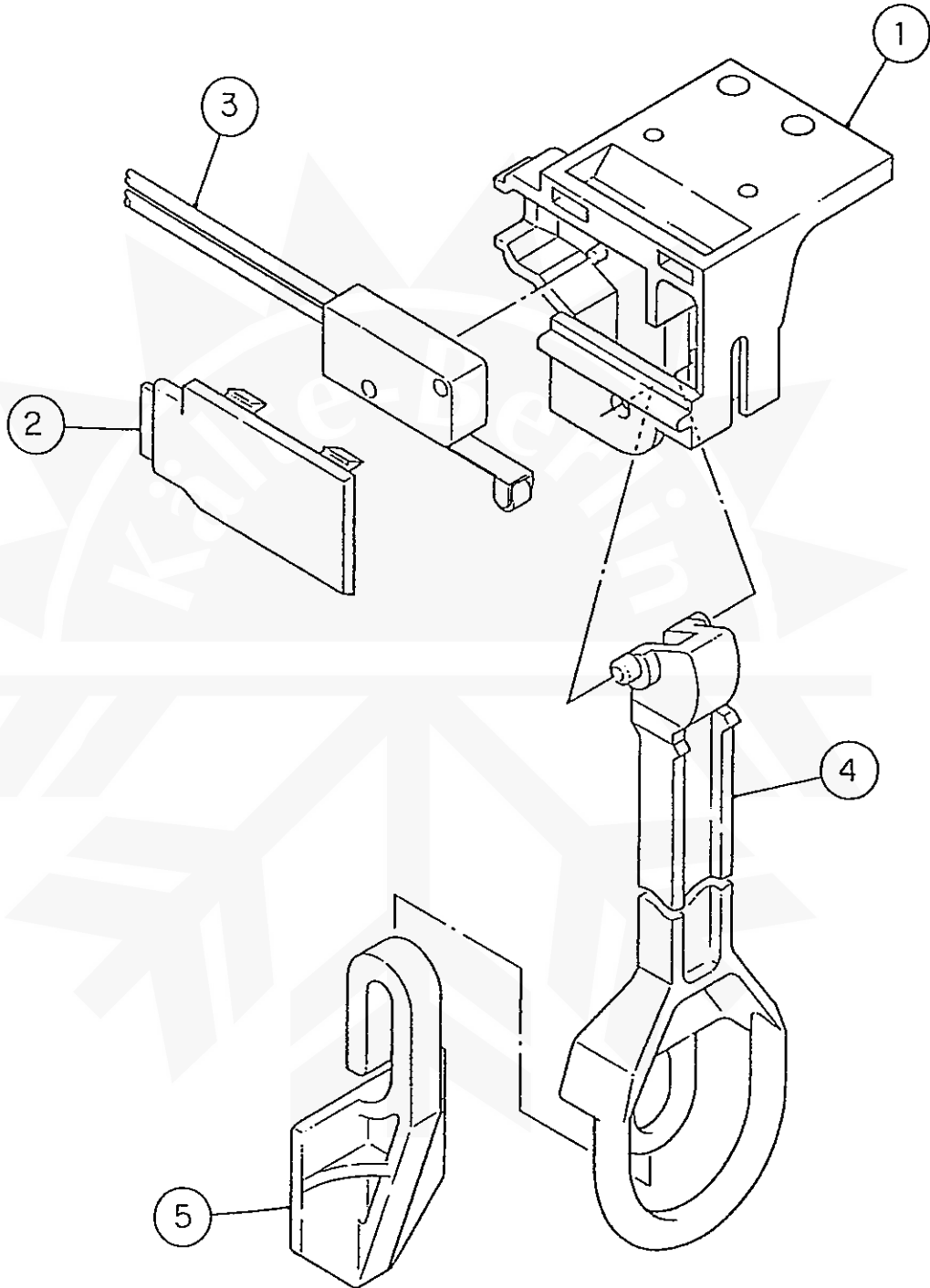

HE, GENERAL, RINNAI, OCEANIA, AUSTRALIA, HSP

MODEL : <b>IM-130ME</b>							
IM-130ME-21,-23				TITLE : <b>J. BIN CONTROL SWITCH ASSY</b>			
INDEX NO.	DESCRIPTION	MATERIAL OR MODEL NUMBER	PART NUMBER	REQ'D NUMBER			
				H-1	H-2 J-0 K-0 A-0 B-0 C-0 D-0	D-1 E-0	E-1 F-0 G-0
1	BRACKET	PC	2H2043-01	1	1	1	1
2	COVER - BRACKET	PC	4H8785-01	1	1	1	1
3	MICROSWITCH	ABV1636618F2	456432-02	1	1	1	1
4	ACTUATOR	PC	3H1369-02	1	1	1	1
5	DETECTOR	ABS	311044-01	1	1	1	1

**HE, GENERAL, RINNAI, OCEANIA, AUSTRALIA, HSP, CHINA**

<b>MODEL : IM-130ME, IM-130ME-21</b>							
<b>IM-130ME-23, IM-130ME-C</b>				<b>TITLE: J. BIN CONTROL SWITCH ASSY</b>			
INDEX NO.	DESCRIPTION	MATERIAL OR MODEL NUMBER	PART NUMBER	REQ'D NUMBER			
				G-1	G-2 T-0	T-1,U-0 V-0,L-0	
1	BRACKET	PC	2H2043-01	1	1	1	
2	COVER - BRACKET	PC	4H8785-01	1	1	1	
3	MICROSWITCH	ABV1636618F2	456432-02	1	1	1	
4	ACTUATOR	PC	3H1369-02	1	1	1	
5	DETECTOR	ABS	311044-01	1	1	1	

IM-130ME  
IM-130ME-21, -23  
IM-130ME-C

K. WATER PAN ASSY

(D-1) (E-0) (E-1) and later  
(A-0) (B-0) (C-0) (D-0)  
(H-1) (H-2) (J-0) (K-0)

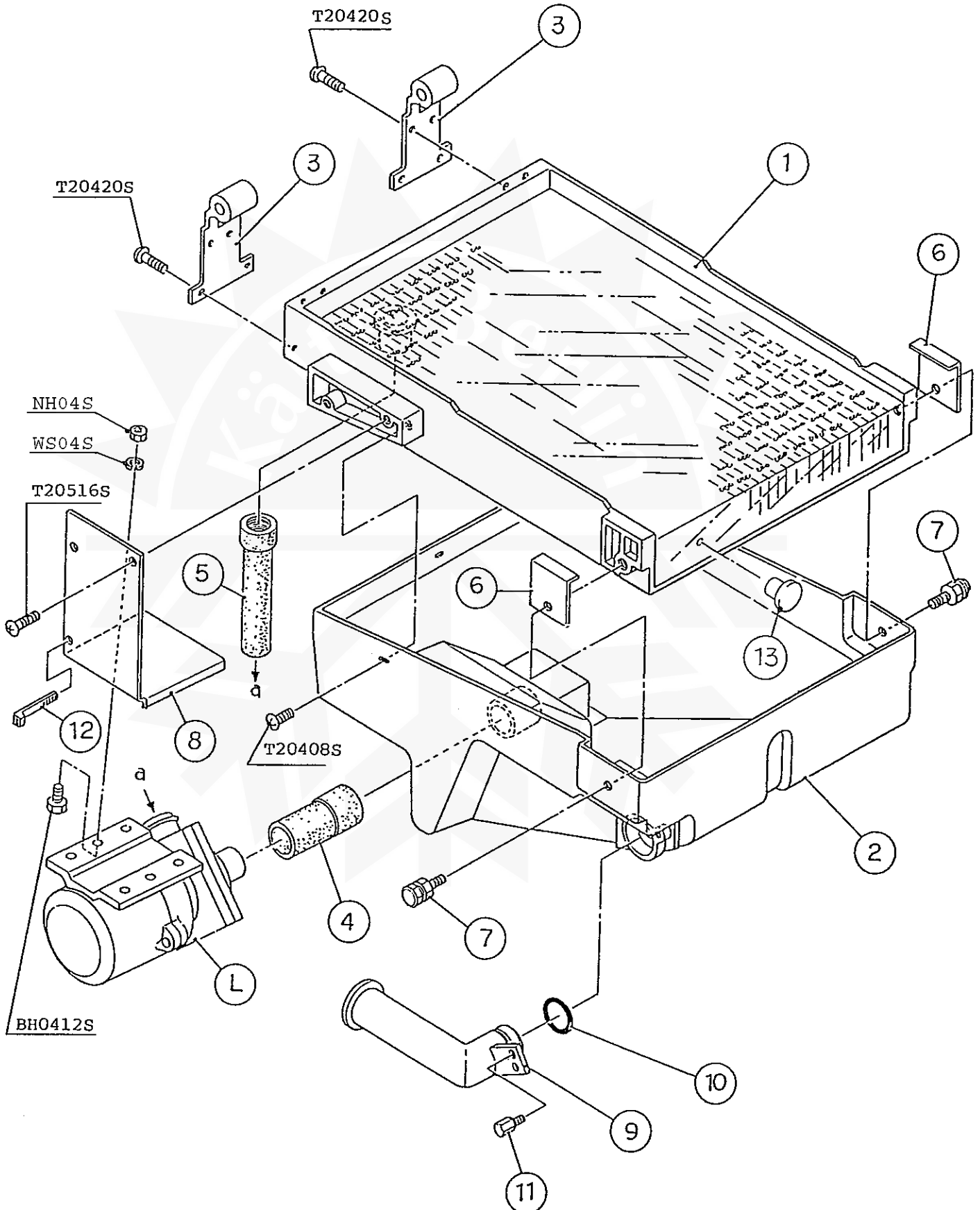







IM-130ME  
IM-130ME-21, -23  
IM-130ME-C

L. WATER PUMP ASSY

(D-1) (E-0) (E-1) and later  
(A-0) (B-0) (C-0) (D-0)  
(H-1) (H-2) (J-0) (K-0)

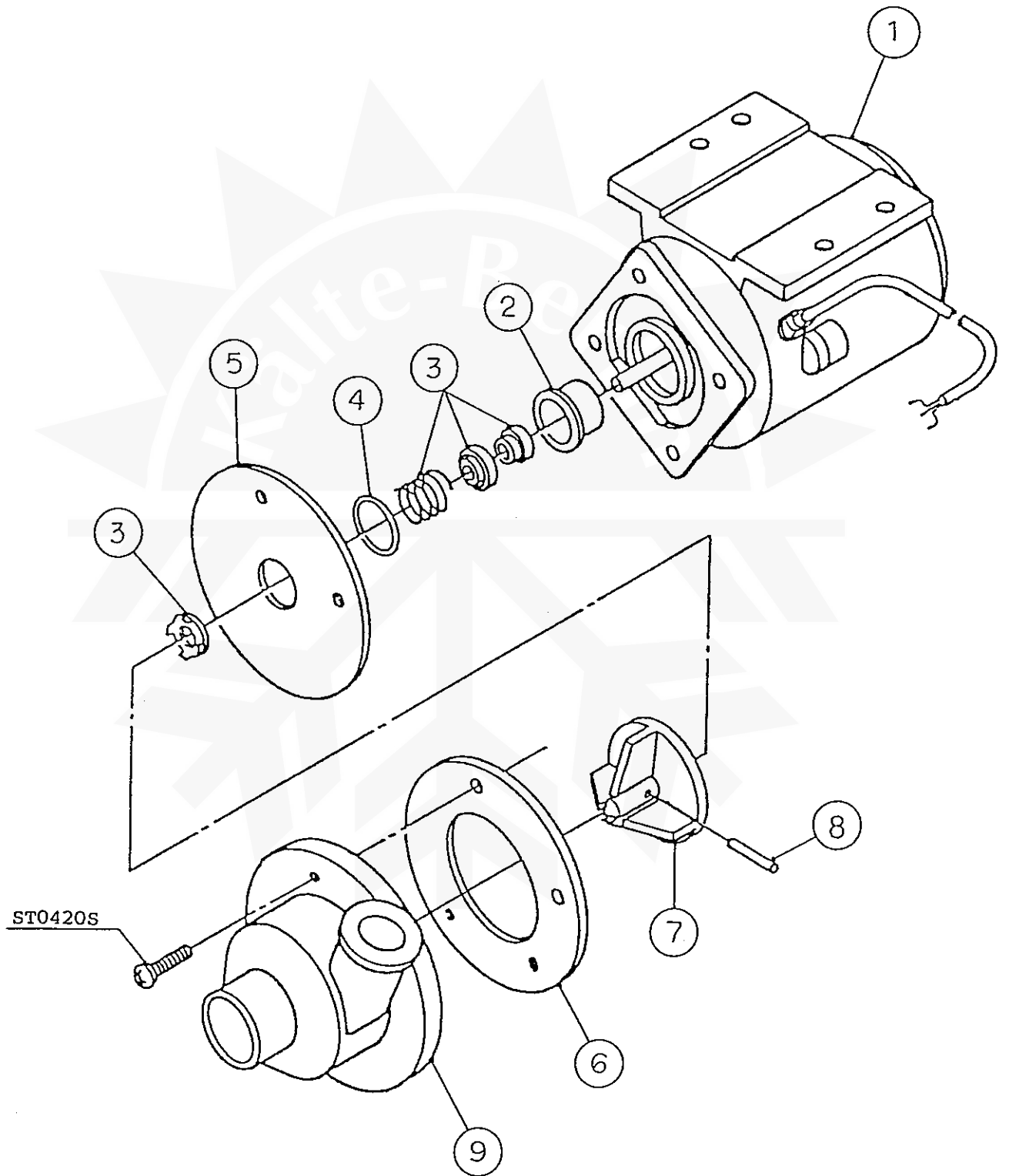





IM-130ME  
IM-130ME-21, -23  
IM-130ME-C

M. ACCESSORIES

(D-1) (E-0) (E-1) and later  
(A-0) (B-0) (C-0) (D-0)  
(H-1) (H-2) (J-0) (K-0)

