

Thea

H 92
P 120
L 110 • 140

3M1 3M2 meat • sandwiches • drinks • dairy • fresh products

AG	EF	TN	TB	TB/TN	TC	TC/TN	N
		Chiller	Freezer	Dual Temp	Heated	Hot&Cold	Non-refrigerated
RS - Static							
RV - Ventilated							
RS/TC S - Static and Dry Heat convertible							
RV/TC S - Ventilated / Dry Heat convertible							
HUR - Meat							
CH - Chocolate							
TC S - Dry Heat							
TC BM - Bainmarie							
N - Non-refrigerated							

Panoramic and multiplexable promotional island display for fresh and packaged products

Installation
Plug-in

Temperature range
• 0 / +2 °C (110)
• +2 / +4 °C (140)

Refrigerant
• R290
• R452A (Non-Eu markets only)

Refrigeration
Ventilated

Defrost
Compressor off

Climate and product class
• 3M1 (110)
• 3M2 (140)

Illumination
LED

Isola promozionale panoramica e canalizzabile, per prodotti freschi e preconfezionati

Installazione
Plug-in

Temperatura di esercizio
• 0 / +2 °C (110)
• +2 / +4 °C (140)

Refrigerante
• R290

Refrigerazione
Ventilata

Sbrinamento
Fermata compressore

Classe climatica e di prodotto
• 3M1 (110)
• 3M2 (140)

Illuminazione
LED

Available colours
Colori disponibili

● Standard / Di serie
□ On request

Inside
Interno

- RAL 9005 Black
- White
- RAL 7012 Grey
- RAL 7016 Grey

Outside
Esterno

- RAL 9005 Black
- White
- RAL 7012 Grey
- RAL 7016 Grey

Plinth
Basamento

- RAL 9005 Black
- White
- RAL 7012 Grey
- RAL 7016 Grey



Thea

	110	140
External dimensions (LxDxH) with bumper Dimensioni esterne (LxPxH) con batticarrello	1200 x 1200 x 920 mm	1500 x 1200 x 920 mm
Capacity (gross/net) Capacità (lorda/netta)	345/228 lt	445/292 lt
Net weight Peso netto	154	192
Refrigeration Refrigerazione	Ventilated - Ventilata	
Refrigerant Refrigerante	R290 / R452A (Non-Eu markets only)	
Climatic class Classe climatica	3	
Operating conditions Condizioni ambientali	25 °C / 60 %RH	
Product temperature Temperatura prodotto	-1 / +5 °C	-1/+7 °C
Compressor (q.ty-type) Compressore (q.tà-tipologia)	1 Hermetic - 1 Ermetico	
Defrost Sbrinamento	Off Cycle - Fermata compressore	
Power supply Alimentazione	230 V / 1 Ph / 50 Hz	
Electrical input (nominal) Assorbimento elettrico (regime)	R290 420 W / 2,7A	590 W / 2,9 A
	R452A 1000 W / 5.2 A	1000 W / 5.2 A
Electrical input (defrost) Assorbimento elettrico (sbrinamento)	R290 45 W / 0,3 A	45 W / 0,3 A
	R452A 170 W / 0.8 A	170 W / 0.8 A

Height	Length	Model type	Total display area	Temperature class	Recommended temperature	Energy class	Energy efficiency index	Annual energy consumption	Light source type and class
Altezza	Lunghezza	Tipo di banco	Superficie espositiva totale m ²	Classe di temperatura	Temperatura consigliata °C	Classe energetica	Indice di efficienza energetica EEI	Consumo annuo AEC kWh/A	Tipo e classe illuminazione
H92	110	IHC4	1,44	M1	+2°C	F	65,68	2.489	-
	140	IHC4	1,79	M2	+4°C	E	65,04	2.811	-

Configuration: air-cooled plug-in unit R290, LED lighting 5700K
Configurazione: unità condensatrice plug-in R290, illuminazione LED 5700K

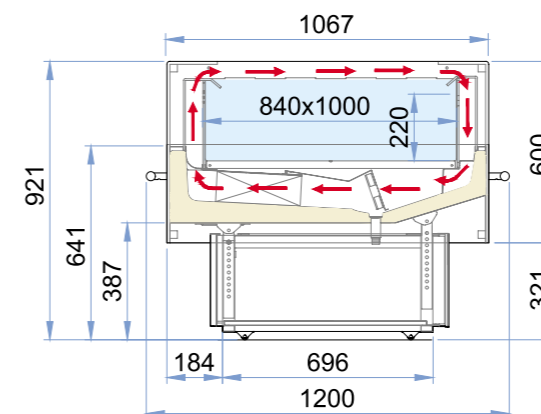

Thea



Thea with sliding lids
(optional)