

Indigo® Series 1406 Ice Cube Machine

Model: ID-1406A ID-1406W ID-1496N
 IY-1406A IY-1406W IY-1496N



Indigo Series i-1406
Ice Machine on B-970 Bin

Designed for operators who know that ice is critical to their business, the Indigo® Series ice machine's preventative diagnostics continually monitor itself for reliable ice production. Improvements in cleanability and programmability make your ice machine easy to own and less expensive to operate. New levels Performance showcasing improved ice harvest along with reductions in energy consumption.

- **New Levels of Performance** – showcasing reduction in energy consumption and improved ambient ice production: up to 11% reduction in energy and up to 11% increase in ice production. Watt consumption /100 lbs. of ice is also reduced 15%.
- **EasyRead Display** – communicates operating status, cleaning reminders, and asset information through a blue illuminated display.
- **Programmable Ice Production** – by On/Off Time, Ice Volume or Bin Level (with accessory bin level control) further improves energy efficiency and savings.
- **Easy to Clean Foodzone** – Hinged front door swings out for easy access. Removable water-trough, distribution tube, curtain, and sensing probes for fast and efficient cleaning. Select components made with AlphaSan® antimicrobial.
- **Intelligent Diagnostics** – provide 24 hour preventative maintenance and diagnostic feedback for trouble free operation.
- **Acoustical Ice Sensing Probe** – for reliable operation in challenging water conditions.
- **DuraTech™ Exterior** – provides superior corrosion resistance. Stainless finish with innovative clear-coat resists fingerprints and dirt.
- Available **LuminIce™ Growth Inhibitor** controls the growth of bacteria and yeast within the foodzone.

Ice Machine Electric

208-230/60/1 standard
(208-230/60/3 and 230/50/1 also available.)

Minimum circuit ampacity:

| | | |
|----------------|----------|----------|
| Air-cooled: | 15.9 1ph | 12.3 3ph |
| Water-cooled: | 14.3 1ph | 11.3 3ph |
| Remote-cooled: | 14.9 1ph | 12.3 3ph |

Maximum fuse size:

| | | |
|----------------|--------|--------|
| Air-cooled: | 25 1ph | 20 3ph |
| Water-cooled: | 25 1ph | 20 3ph |
| Remote-cooled: | 25 1ph | 20 3ph |

Specifications

BTU Per Hour:

23,500 (average)
27,000 (peak)

Refrigerant:

R-404A CFC-free

Operating Limits:

- Ambient Temperature Range: 35° to 110°F (1.7° to 43.3°C)
Water Temperature Range: 35° to 90°F (1.7° to 32.2°C)
- Water Pressure Ice Maker Water In:
Min. 20 psi (137.9 kPa)
Max. 80 psi (551.1 kPa)



Ice Shape



Half Dice
3/8" x 1 1/8" x 7/8"
(.95 x 2.86 x 2.22 cm)



Dice
7/8" x 7/8" x 7/8"
(2.22 x 2.22 x 2.22 cm)





Indigo® Series 1406 Ice Cube Machine

i-1406 on B-970 Storage Bin

Installation Note

Air Cooled clearance:

Top: 24" (61.0 cm)

Sides: 24" (61.0 cm)

Back: 5" (30.5 cm)

Water Cooled clearance:

Top/Sides: 8" (20.3 cm)

Back: 5" (12.7 cm)

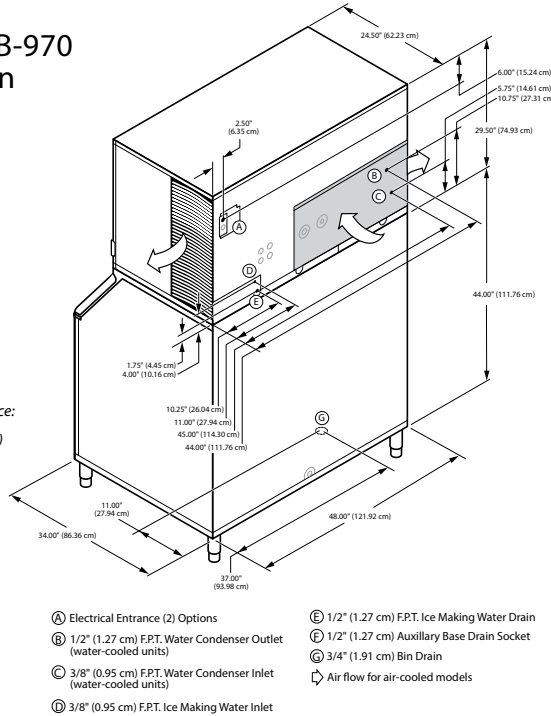

Space-Saving Designs



i-1400 B-970

| | |
|-------------|------------------------|
| Height | 79.50" 201.90 cm |
| Width | 48.00" 121.92 cm |
| Depth | 34.00" 86.30 cm |
| Bin Storage | 710 lbs. 322.2 kgs. |

Height includes adjustable bin legs 6.00" to 8.00", (15.24 to 20.32 cm) set at 6.00" (15.24 cm).

Specifications

| | Model | Ice Shape | Ice Production 24 Hours | | Power Usage kWh/100 lbs. @90°Air/70°F | | Water Usage/ 100 lbs. 45.4 kgs. of Ice | | ENERGY STAR® |
|--|----------|-----------|-------------------------|--------------------|---------------------------------------|------|--|----|--------------|
| | | | 70°Air/ 50°F Water | 90°Air/ 70°F Water | 1 Ph | 3 Ph | Potable Water | | |
| AIR-COOLED | ID-1406A | dice | 1,629 lbs. | 1,235 lbs. | 4.52 | 4.52 | 20 gal. | ★ | |
| | | | 739 kgs. | 560 kgs. | | | 75.7 L. | | |
| AIR-COOLED | IY-1406A | half-dice | 1,659 lbs. | 1,308 lbs. | 4.32 | 4.32 | 20 gal. | ★ | |
| | | | 753 kgs. | 593 kgs. | | | 75.7 L. | | |
| WATER-COOLED | ID-1406W | dice | 1,585 lbs. | 1,325 lbs. | 3.75 | 3.75 | 20 gal. | NA | |
| | | | 719 kgs. | 601 kgs. | | | 75.7 L. | | |
| WATER-COOLED | IY-1406W | half-dice | 1,587 lbs. | 1,330 lbs. | 3.85 | 3.85 | 20 gal. | NA | |
| | | | 720 kgs. | 603 kgs. | | | 75.7 L. | | |
| * Water-cooled Condenser Water Usage / 100 lbs. /45.4 kgs. Of Ice: 154 gal. / 583 L. | | | | | | | | | |
| * Water-cooled models are excluded from ENERGY STAR qualification. | | | | | | | | | |
| REMOTE-COOLED | ID-1496N | dice | 1,539 lbs. | 1,295 lbs. | 4.22 | 4.22 | 20 gal. | ★ | |
| | | | 698 kgs. | 587 kgs. | | | 75.7 L. | | |
| REMOTE-COOLED | IY-1496N | half-dice | 1,588 lbs. | 1,305 lbs. | 4.23 | 4.23 | 20 gal. | ★ | |
| | | | 707 kgs. | 592 kgs. | | | 75.7 L. | | |

Order ice storage bin separately. To order 3 phase add "3" suffix to model # (ID-1202A3).

Accessories

LuminIce™ Growth Inhibitor reduces yeast and bacteria growth for a cleaner ice machine.



Bin Level Control Allows ice bin level to be automatically set. Built-in LED light illuminates bin.



Arctic Pure® Water Filters Reduces sediment and chlorine odors for better tasting ice.



AuCS® schedules and performs routine ice machine cleaning automatically.

