

NOTE: COMPONENT AND ASSEMBLY MUST BE COMPLIANT TO APPLICABLE RECENT ROHS DIRECTIVES.

CHANGE NOTE						
REVISION	SHEET NO	ZONE	DETAILS	ECN	DATE	DRAWN
B	1.2	-	DRAWING UPDATED	-	08.08.2022	SHARAD

	DIM 'A'
ADJUSTABLE LEG 100-130mm	100mm
ADJUSTABLE LEG 130-200mm	130mm
CASTOR WHEEL	125mm

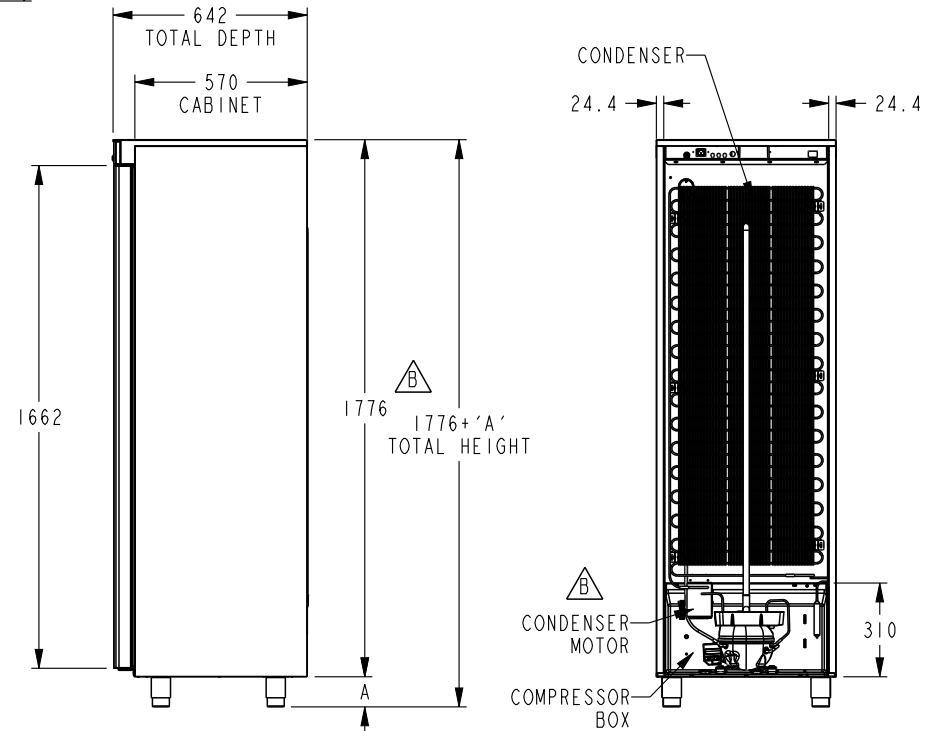
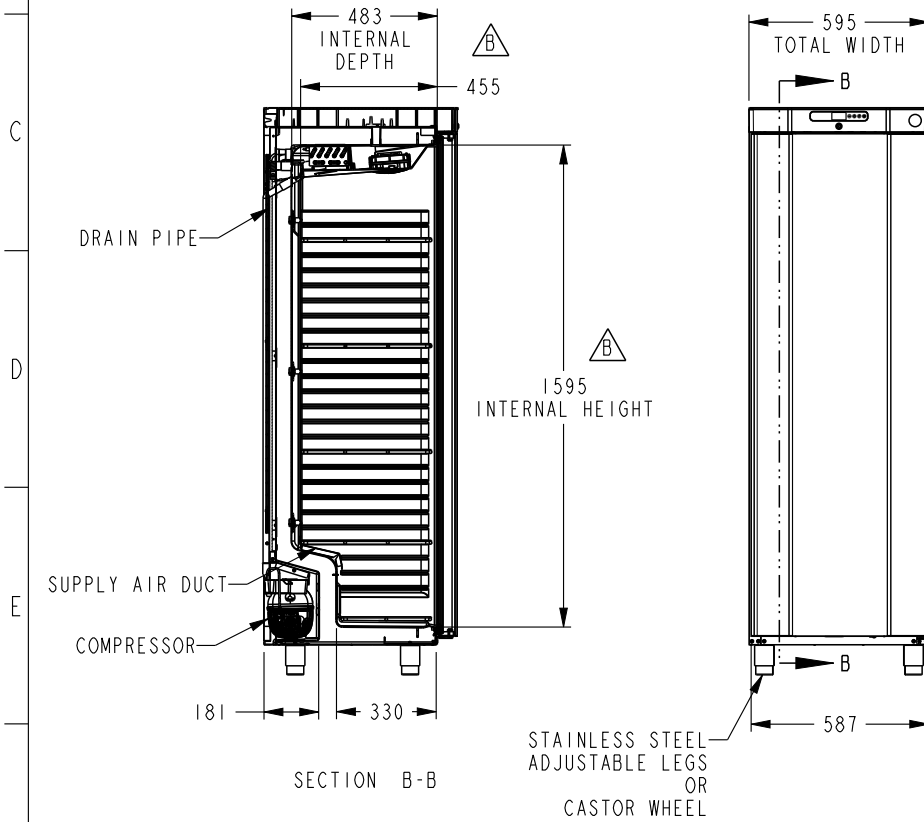
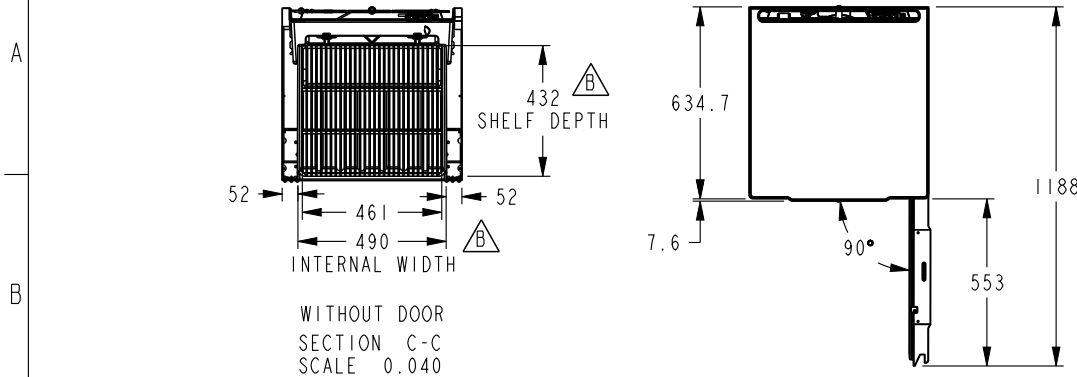

UNSPECIFIED TOLERANCES				SCALE: NTS	TITLE	DWG. NO:	REVISION	
DIM	<6	6-30	30-120	120-400	400-1000	>1000	0711058	B
TOL	±0.1	±0.2	±0.3	±0.5	±0.8	±1.2	SAP CODE 0711058	
UNSPECIFIED TOL. ON ANGLE ±0.5				ALL DIMENSIONS ARE IN MM	GENERAL ARRANGEMENT			
1 "O" DIMENSIONS ARE IMPORTANT.				DRAWN BY SAURABH S	MODEL K/F 420			
2 REFERENCE DIMENSIONS ARE MARKED WITH " () "				CHECKED BY BHASKAR	RELEASE DATE 02.08.2021	SHEET 1 OF 2		
3 PART SHOULD BE FREE FROM SHARP EDGES & BURRS				APPROVED BY PARESH	RELEASE STAGE: IN WORK			
REFERENCE STANDARD								

THIS ASSEMBLY DRAWING IS FOR ILLUSTRATION PURPOSE. COMPONENTS, ASSEMBLY SEQUENCE MAY VARY DEPENDING UPON MANUFACTURING PRACTICES SPECIFIC TO MANUFACTURING LOCATIONS. REFER PROCESS WORK INSTRUCTIONS FOR MORE DETAILS ON ASSEMBLY. REFER SAP BOM FOR EXACT MATERIAL CONSUMPTION.

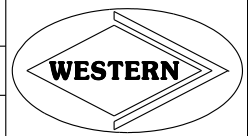

NOTE: COMPONENT AND ASSEMBLY MUST BE COMPLIANT TO APPLICABLE RECENT ROHS DIRECTIVES.

	ITEM	UPRIGHT SOLID DOOR CHILLER	UPRIGHT SOLID DOOR FREEZER
	MODEL NAME	COMPACT K420	COMPACT F420
⚠	POWER SUPPLY	SINGLE PHASE, 220-240V AC, 50HZ	SINGLE PHASE, 220-240V AC, 50HZ
	POWER CORD	3M / AMPERAGE AS PER COUNTRY SPECIFICATION	3M / AMPERAGE AS PER COUNTRY SPECIFICATION
⚠	OUTSIDE DIMENSIONS (mm)	595(W)X642(D)X1776+A(H)	595(W)X642(D)X1776+A(H)
	INSIDE DIMENSIONS (mm)	490(W)X483(D)X1595(H)	490(W)X483(D)X1595(H)
	EXTERIOR MATERIAL	PRE-COATED SHEET / STAINLESS STEEL SS430	PRE-COATED SHEET / STAINLESS STEEL SS430
	INTERIOR MATERIAL	HIPS	HIPS
	INSULATION	POLYURETHANE FOAM (CFC FREE)	POLYURETHANE FOAM (CFC FREE)
	INSULATION FOAM BLOWING AGENT	CYCLOPENTANE	CYCLOPENTANE
	REFRIGERATION SYSTEM	FORCED COOLING	FORCED COOLING
	COMPRESSOR	EMBRACO	EMBRACO
	CONDENSER	WIRE ON TUBE TYPE	WIRE ON TUBE TYPE
	EVAPORATOR	COPPER TUBE	COPPER TUBE
	REFRIGERANT	R600a	R600a
⚠	OPERATING CONDITIONS	CLIMATIC CLASS4 : +30°C / 55% RH	CLIMATIC CLASS4 : +30°C / 55% RH
	TEMPERATURE RANGE	+1°C TO +12°C	-25°C TO -5°C
	CASTOR / LEGS	4NOS OF ADJUSTABLE LEGS (100-130mm) OR 4NOS OF ADJUSTABLE LEGS (130-200mm) OR 4NOS OF CASTOR WHEELS (125mm)S	4NOS OF ADJUSTABLE LEGS (100-130mm) OR 4NOS OF ADJUSTABLE LEGS (130-200mm) OR 4NOS OF CASTOR WHEELS (125mm)
	SHELF	4NO BIG SHELF + 1NO SMALL SHELF	4NO BIG SHELF + 1NO SMALL SHELF

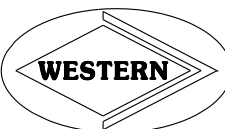
SCALE: NTS  ALL DIMENSIONS ARE IN MM	TITLE		DWG. NO:	REVISION
	GENERAL ARRANGEMENT		0711058	B
DRAWN BY	MODEL		SAP CODE	
SAURABH S	K/F 420		0711058	
CHECKED BY	RELEASE DATE	SHEET		
BHASKAR	02.08.2021	2 OF 2		
APPROVED BY	RELEASE STAGE:			
PARESH	IN WORK			