



ZANOTTI Spa
 Via M.L. King, 30
 46020 - Pegognaga (MN) - ITALY
 Tel. +39 0376 5551
 Fax +39 0376 536554
 info@zanotti.com

Datenblatt

Ausführung 2.0

Modell:

Kategorie:

SB.MSP212EA11XX

SP-O

Technische Daten

Eigenschaften	M.U.	Wert
Betriebstemperatur	°C	+10 ÷ -5
Art des Antriebs		Direkt
Spannung	Volt-Ph-Hz	230/1~/50
Nennaufnahme	kW*	1,70
Nennaufnahme	Amp*	4,60
Anlaufstrom	Amp	27,0
Strom max.	Amp	9,3
Kühlmittel		R134a
	GWP	1430
Abtauzyklus		Elektrisch
Abtauheizung	watt	800
Gewicht	Kg	59
Kondensationseinheit		
Verdampfer Gewicht	Kg	19

Kompressor

Typ		Hermetisch
Nennleistung	kW	0,9

Kondensator

Luftmenge	m ³ /h	1400
-----------	-------------------	------

Verdampfer

Luftmenge	m ³ /h	1200
Wurfweite	m**	4

Kategorie PED		0
---------------	--	---



Leistungsdaten

Tc °C	Ta °C	P watt	P Kcal/h	V100 m ³	V80 m ³	V60 m ³
	20	2863	2462	32	29	27
	25	2719	2338	29	26	24
10	30	2562	2203	27	25	22
	35	2399	2063	25	23	21
	40	2237	1924	22	20	18
	45	2085	1793	20	18	17
	20	2478	2131	26	24	22
	25	2286	1966	23	21	19
5	30	2159	1857	21	19	17
	35	2061	1772	19	17	16
	40	1954	1680	18	16	15
	45	1802	1550	17	15	14
	20	2105	1810	20	18	17
	25	1948	1675	18	16	15
0	30	1816	1562	17	15	14
	35	1702	1464	16	15	13
	40	1601	1377	14	13	12
	45	1507	1296	13	12	11
	20	1746	1502	16	15	13
	25	1595	1372	14	13	12
-5	30	1485	1277	13	12	11
	35	1399	1203	12	11	10
	40	1318	1133	11	10	9,1
	45	1225	1054	9,9	9	8,2

Berechnung der Kälte Leistung und des Raum Volumens

Ta °C

Tc °C

PF Watt

Kcal/h

V100 m³

V80 m³

V60 m³

* Bei Betrieb

** Standartwert, der Luftwurf ist von zahlreichen Faktoren abhängig:

Kühlzellenhöhe, Lagerart, Verdampfer Montageort, usw.

Tc: Raumtemperatur. - Ta: Aeussere Temperatur.

P: Abkühlende Kapazität - V: vorgeschlagen Kühlraum Volumen

L'immagine è datata e potrebbe presentare alcune differenze rispetto all'unità attuale. La aggiorneremo il prima possibile.
 The picture is old and it could have some differences from the current unit. We will update it as soon as possible.

Dimensioni - Dimensions - Dimensions
 Abmessungen - Dimensiones

SP2

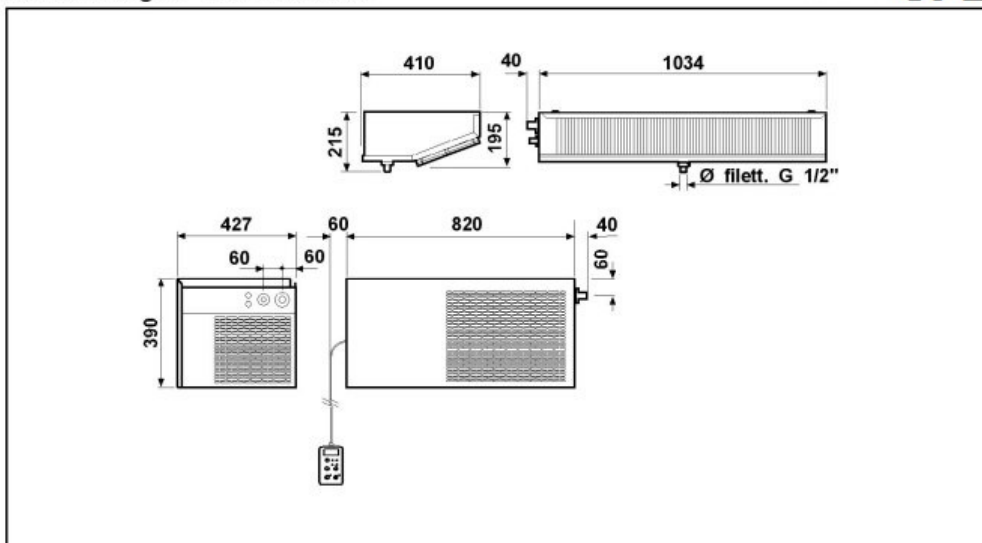

Schema di montaggio - Mounting scheme - Schema de montage
 Montageschema - Esquema de montaje

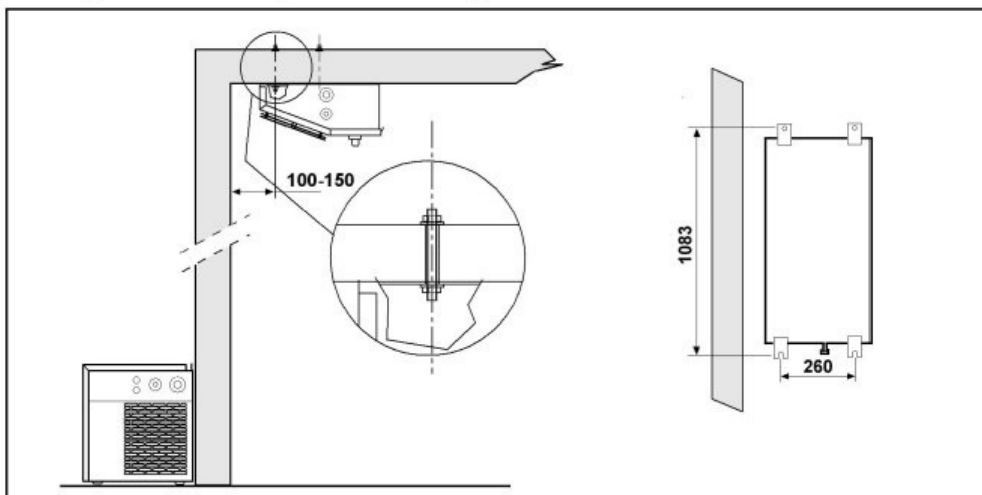

- * Raccomandazioni in sede di installazione e per il controllo fornite sul manuale di installazione
- * To be advised at time of order for factory installation and operating instructions
- * Recommendations au moments d'installations et pour le contrôle fournis sur le manuel d'installation
- * Empfehlungen für die Installationsphase und zur Kontrolle, die im Handbuch zur Installation enthalten sind
- * Por cuanto respecta a recomendaciones de instalación y control ver manual de instalación

Massa e misure imballi - Packing mass and dimensions - Masse et dimensions emballages
 Verpackungsmasse und-abmessungen - Masa y medidas del embalaje

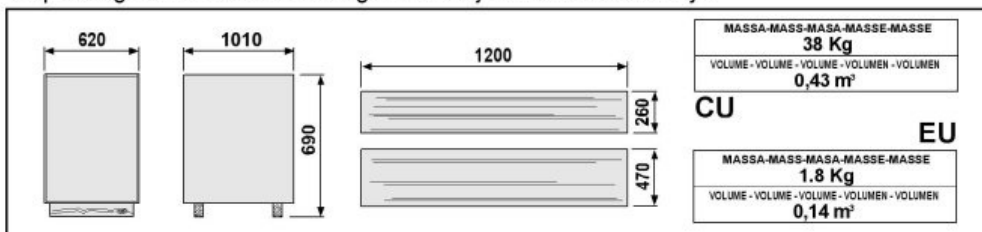

ZANOTTI S.p.A.